

Measurement of ϕ_2 at Belle II

Yu Nakazawa (KEK)

KEK Flavor Factories workshop 2023

February 9th, 2023

Belle II @ SuperKEKB

- ◆ asymmetric e^+e^- collider ($\sqrt{s} = 10.58$ GeV)
 - $e^+e^- \rightarrow \Upsilon(4S) \rightarrow B\bar{B}$
- ◆ Four-momenta of B are well known.
- ◆ Determination of the decay position allows time-dependent analysis.

Luminosity	Design	Accomplished
Integrated	50 /ab (Belle x50)	428 /fb
Peak	6.5×10^{35} /cm ² /s	4.7×10^{34} /cm ² /s

World Record!!

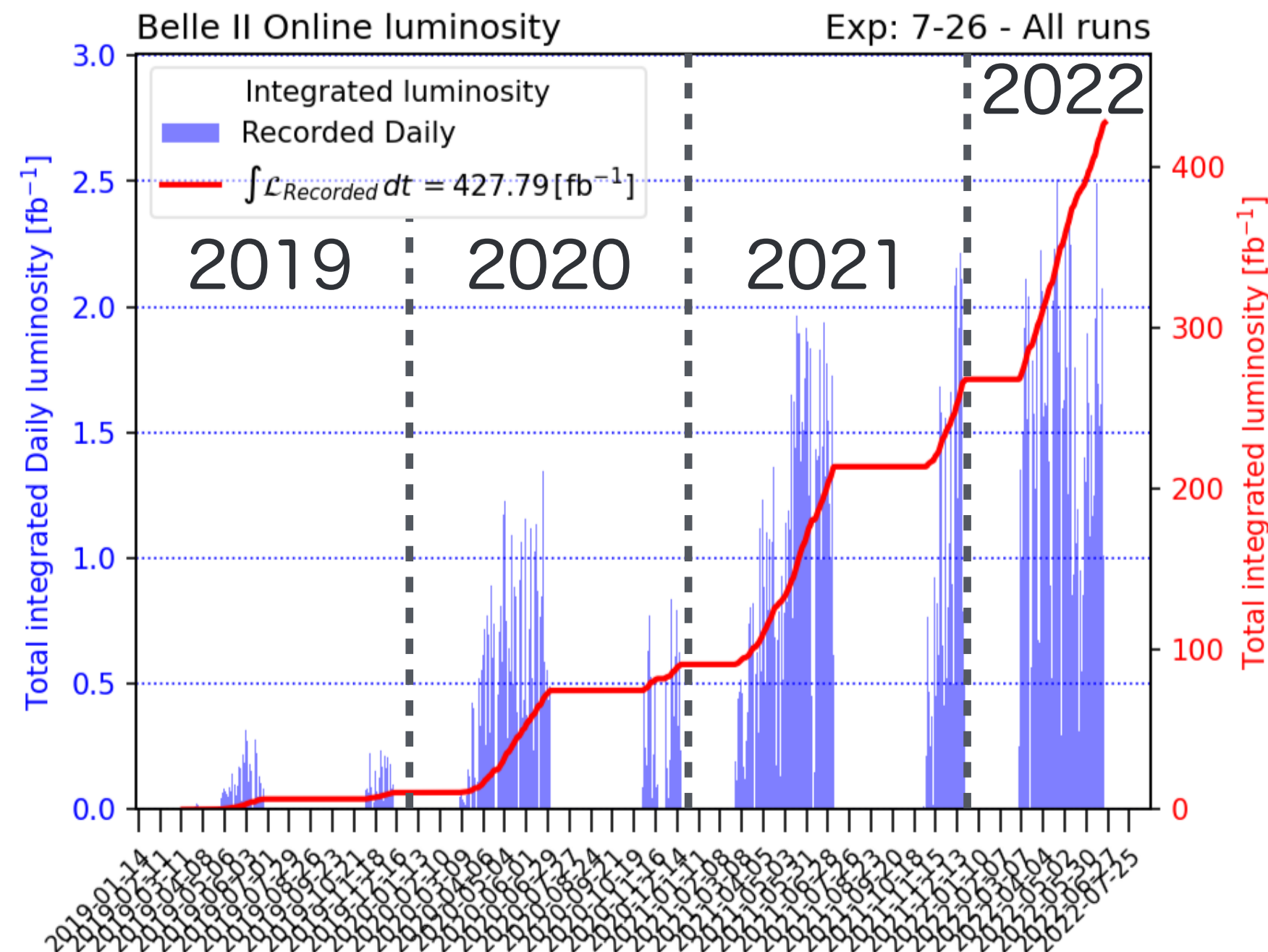

- K_L and μ Detection
K_L⁰ p resolution: 15 MeV
 μ identification eff.: ~90%
- Vertex Detector
vertex resolution: 15 μ m
- Central Drift Chamber
spatial resolution: 100 μ m
dE/dx resolution: 5%
P_T resolution: 0.4%
- EM Calorimeter (CsI)
energy resolution: 1.6%-4%
- Particle Identification
K eff.: 90%, fake π rate: 5%

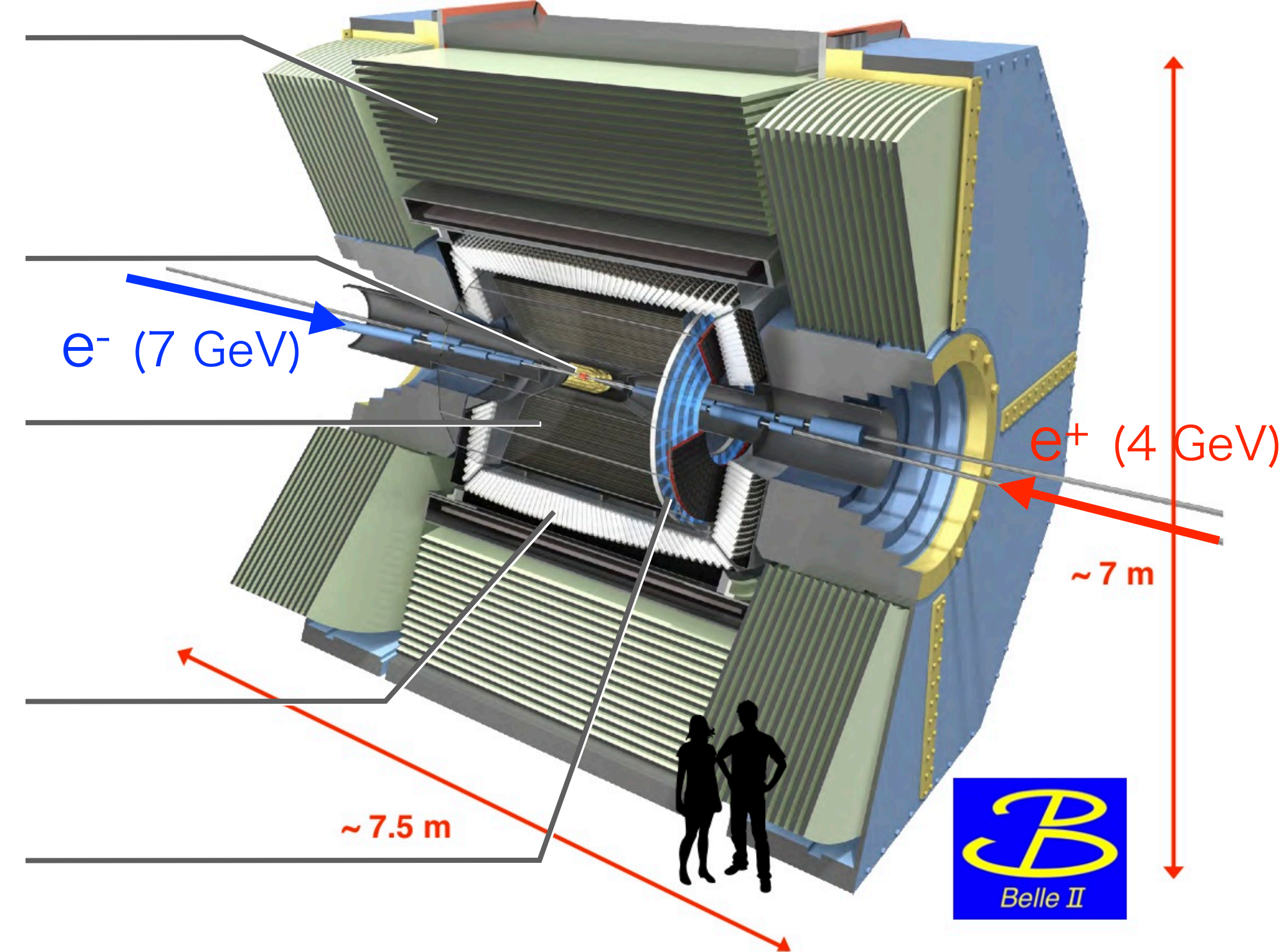

Determination of CKM parameters at Belle II

$$V_{CKM} = \begin{pmatrix} V_{ud} & V_{us} & V_{ub} \\ V_{cd} & V_{cs} & V_{cb} \\ V_{td} & V_{ts} & V_{tb} \end{pmatrix}$$

$$\phi_1 = \arg \left(-\frac{V_{cd}V_{cb}^*}{V_{td}V_{tb}^*} \right) = (22.2 \pm 0.7)^\circ$$

$$\phi_2 = \arg \left(-\frac{V_{td}V_{tb}^*}{V_{ud}V_{ub}^*} \right) = (85.2^{+4.8}_{-4.3})^\circ$$

$$\phi_3 = \arg \left(-\frac{V_{ud}V_{ub}^*}{V_{cd}V_{cb}^*} \right) = (65.9^{+3.3}_{-3.5})^\circ$$

PDG2022

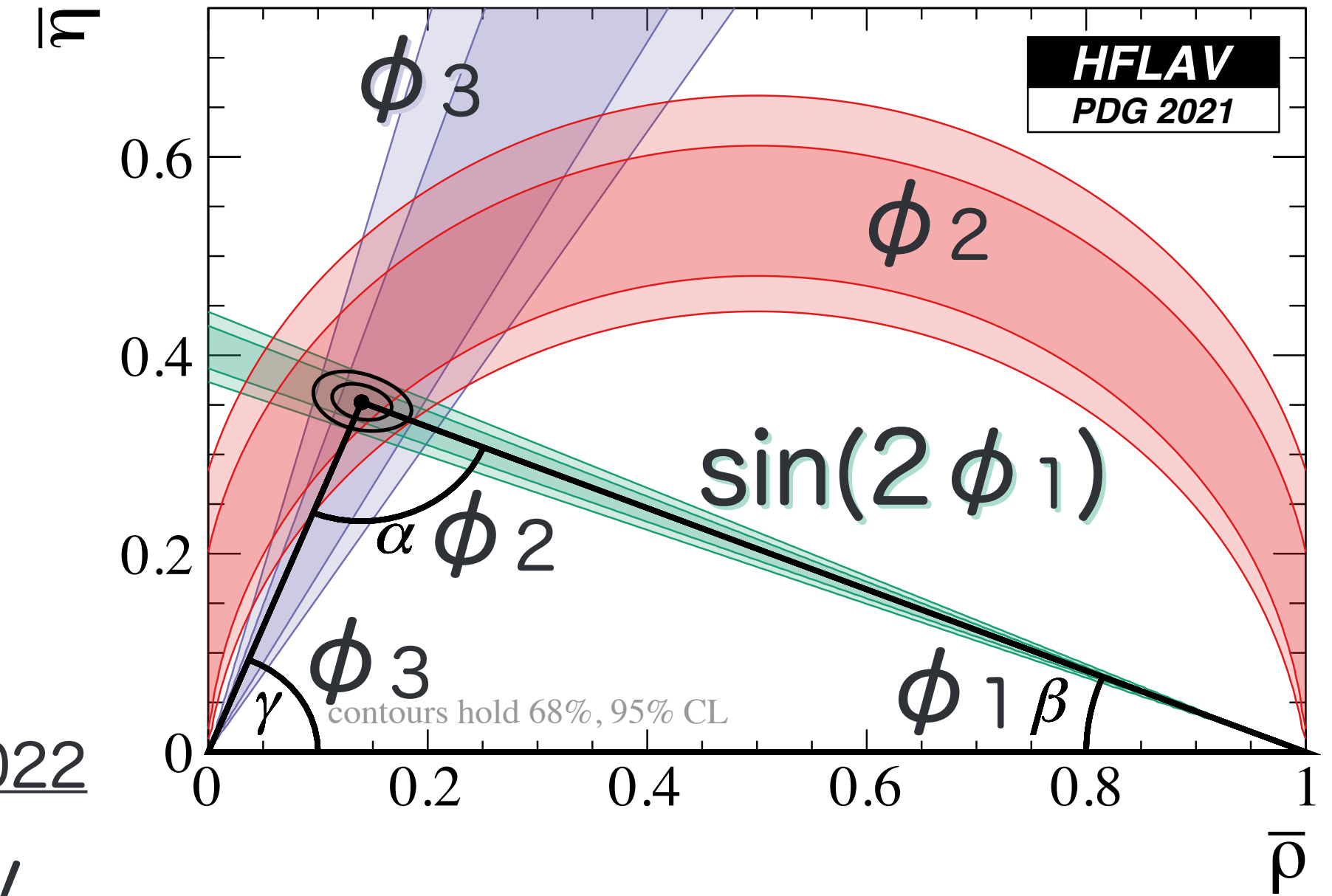

Belle II has the potential to measure more accurately all angles and sides of the unitarity triangle (UT).

- Loop amplitudes provide sensitive probe to new physics.
e.g.) B^0 - \bar{B}^0 mixing ← Time-dependent CP asymmetry measurement

ϕ_2 / α is the least known UT angle

- affected by the penguin contribution in $b \rightarrow d$
- uncertainty: 5.6%

$B \rightarrow \pi\pi$
 $B \rightarrow \rho\rho$
 $(B^0 \rightarrow (\rho\pi)^0)$

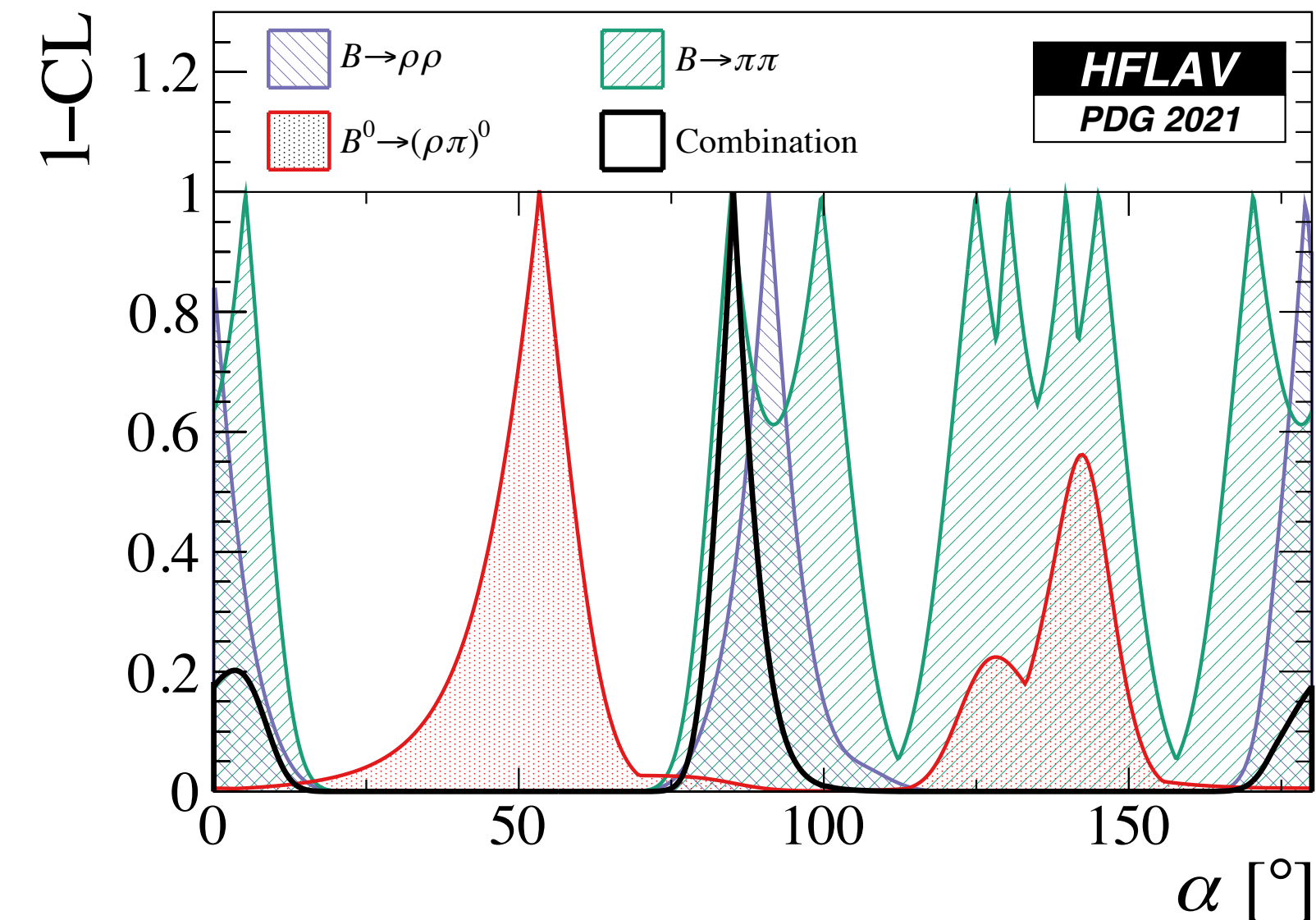

Time-Dependent CP asymmetry measurement

Compare decay widths to determine CP asymmetry

$$\frac{\Gamma(B^0(\Delta t) \rightarrow f) - \Gamma(\bar{B}^0(\Delta t) \rightarrow f)}{\Gamma(B^0(\Delta t) \rightarrow f) + \Gamma(\bar{B}^0(\Delta t) \rightarrow f)} = \mathcal{S}^{B \rightarrow f} \sin(\Delta m_d \Delta t) + \mathcal{A}^{B \rightarrow f} \cos(\Delta m_d \Delta t)$$

mixing-induced CPA
direct CPA

Mixing + Tree

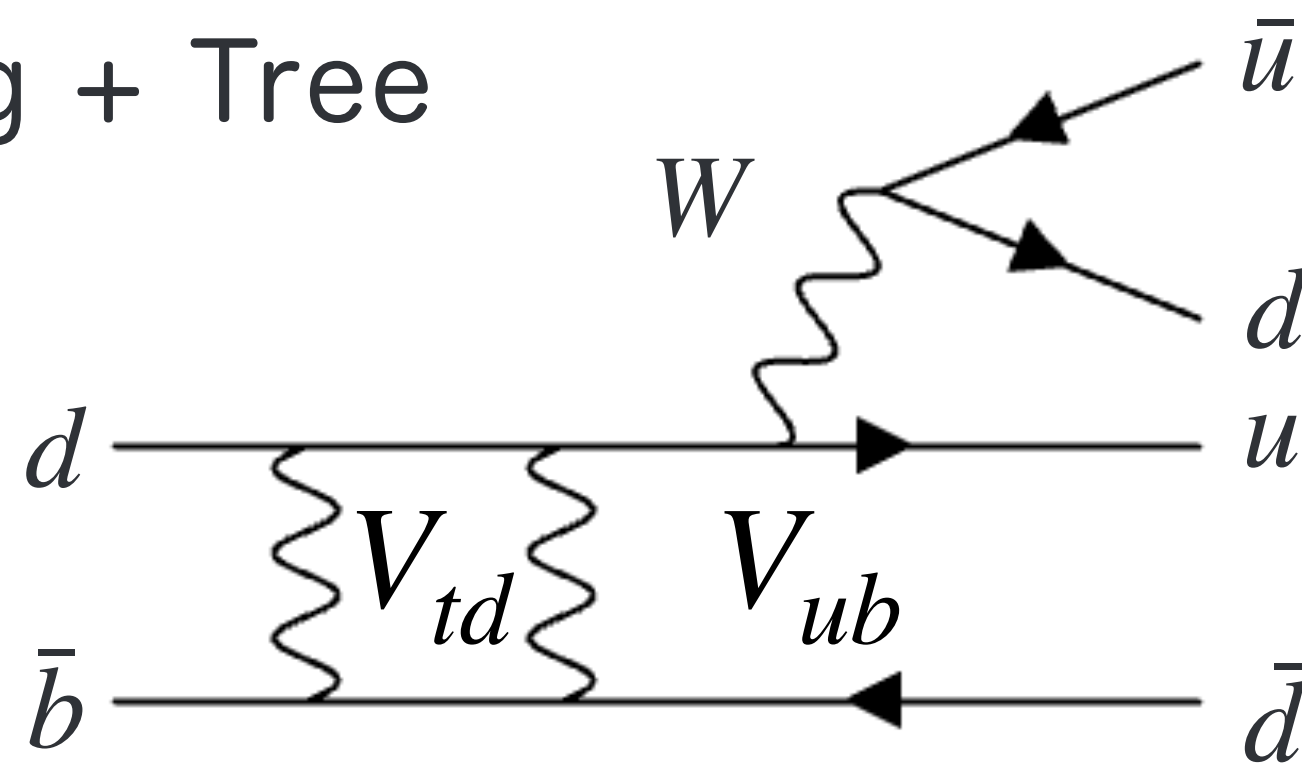

Penguin
(new-physics sensitive)

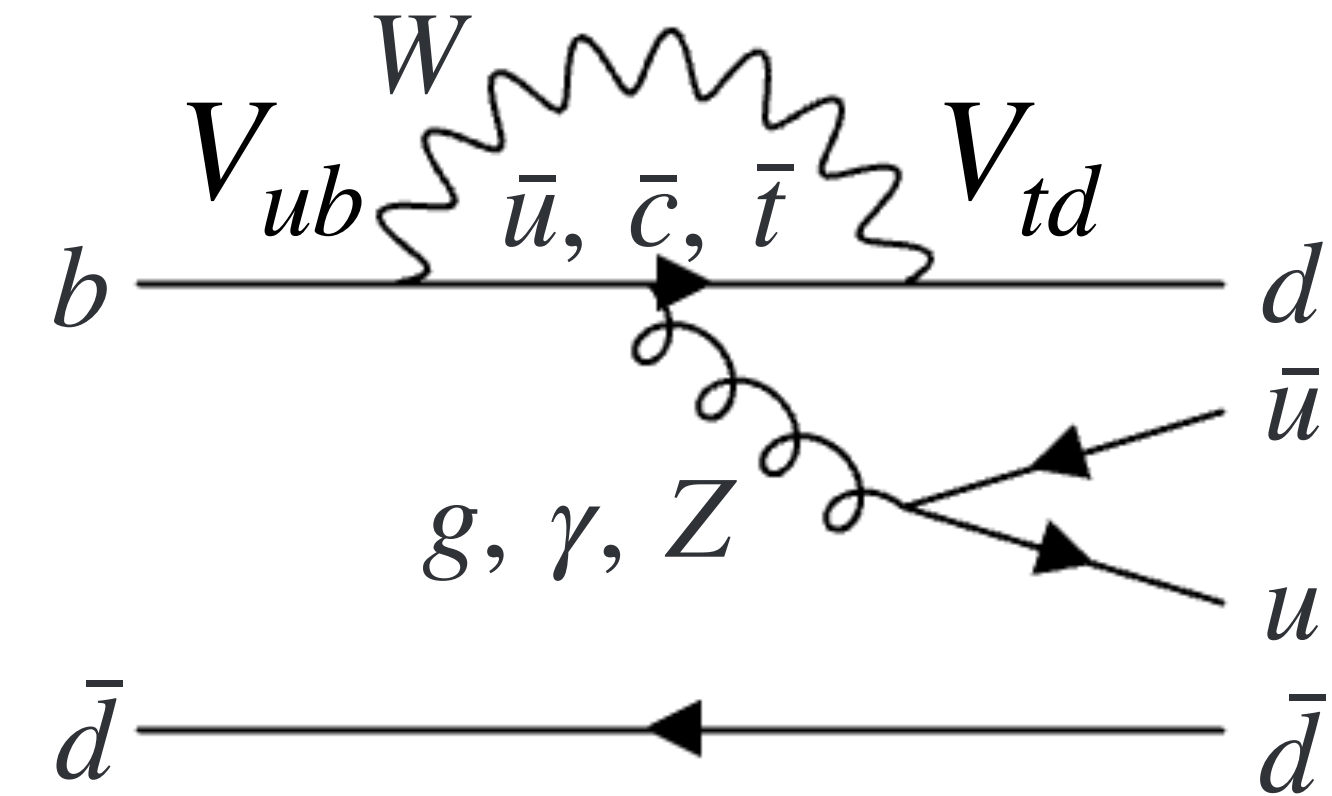

$$B \rightarrow \pi \pi / \rho \rho = [b \rightarrow u \bar{u} d] + [d \text{ or } u]$$

$b \rightarrow u \bar{u} d$: Tree and Penguin processes interfere

- Electro-weak penguin is negligible small.

Result in $\mathcal{A}^{B \rightarrow f} \neq 0$ $\mathcal{S}^{B \rightarrow f} \propto \sin(2\phi_2 + 2\Delta\phi_2)$ ϕ_2 is not explicitly determined...

Need to eliminate the contribution of the penguin process \rightarrow **Isospin analysis**

Isospin analysis in $B \rightarrow \pi \pi$

3 decay modes in $B \rightarrow \pi \pi$ (A_2 : tree only, A_0 : tree + penguin)

$$\pi^+ \pi^- : 1/\sqrt{2} A^{+-} = A_2 - A_0$$

$$\pi^0 \pi^0 : A^{00} = 2A_2 + A_0$$

$$\pi^+ \pi^0 : A^{+0} = 3A_2$$

(Penguin for $\pi^+ \pi^0$ is not allowed.)

$$\left. \begin{array}{l} 1/\sqrt{2} A^{+-} = A_2 - A_0 \\ A^{00} = 2A_2 + A_0 \end{array} \right\} 1/\sqrt{2} A^{+-} + A^{00} = A^{+0}$$

$$\text{CP conjugate: } \left(1/\sqrt{2} \bar{A}^{+-} + \bar{A}^{00} = \bar{A}^{+0} \right)$$

Isospin triangle (PRL 65, 3381, 1990)

devised by M. Gronau and D. London

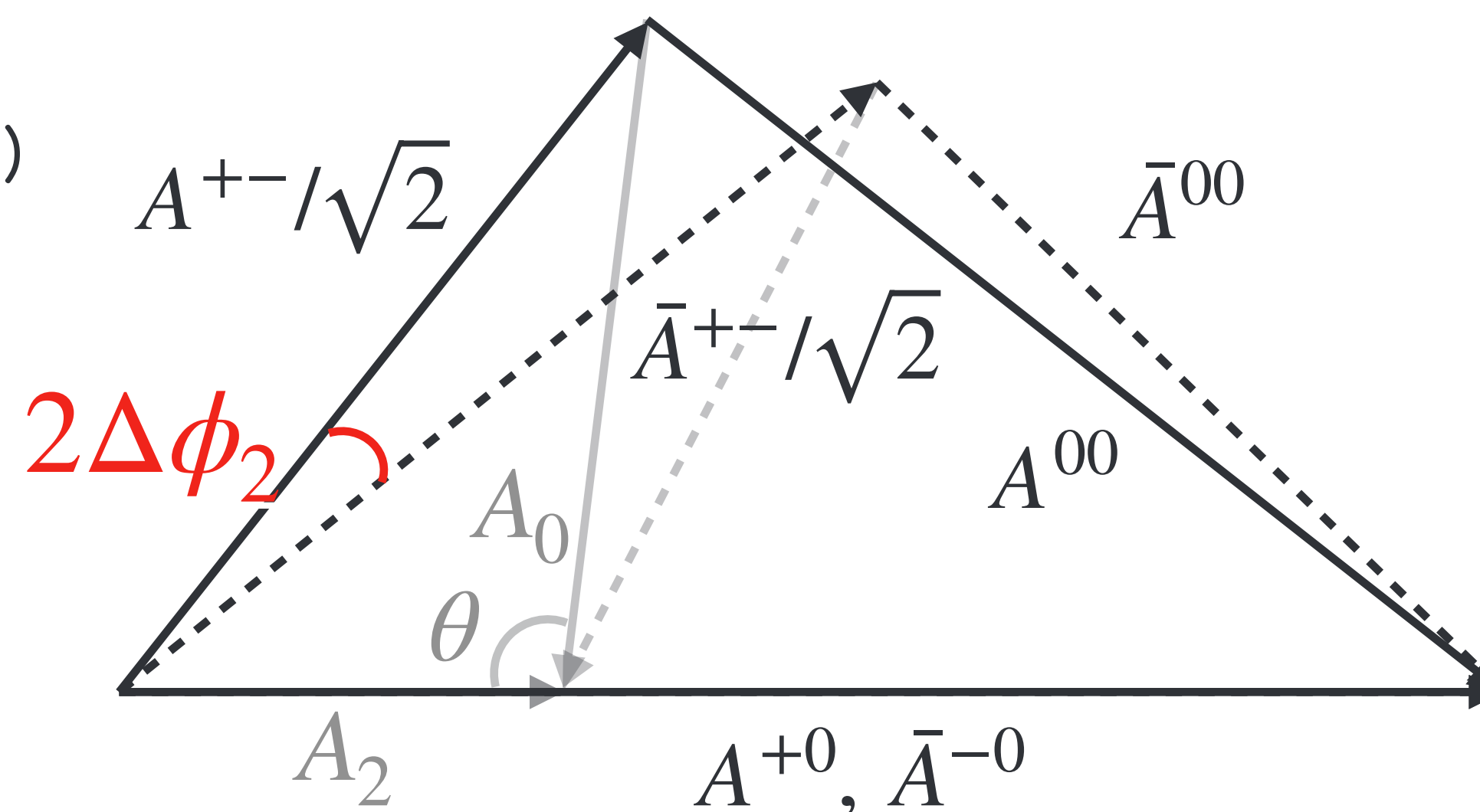

By using $\mathcal{S}^{B \rightarrow f}$, $\mathcal{A}^{B \rightarrow f}$, and BFs, the magnitude of θ is determined, its sign is not.

\Rightarrow Multiple candidates of ϕ_2 are available. (8th-fold ambiguity for $\pi \pi$)

Isospin analysis in $B \rightarrow \rho \rho$

Mode	Process		CP conversion preserves amplitude.	BF ($\times 10^{-6}$)
	Tree	Penguin		
$\rho^+ \rho^-$	○	○	no	27.7 ± 1.9
$\rho^0 \rho^0$	○	○	no	0.96 ± 0.15
$\rho^+ \rho^0$	○	X	yes	24.0 ± 1.9

$\sim 1/25$

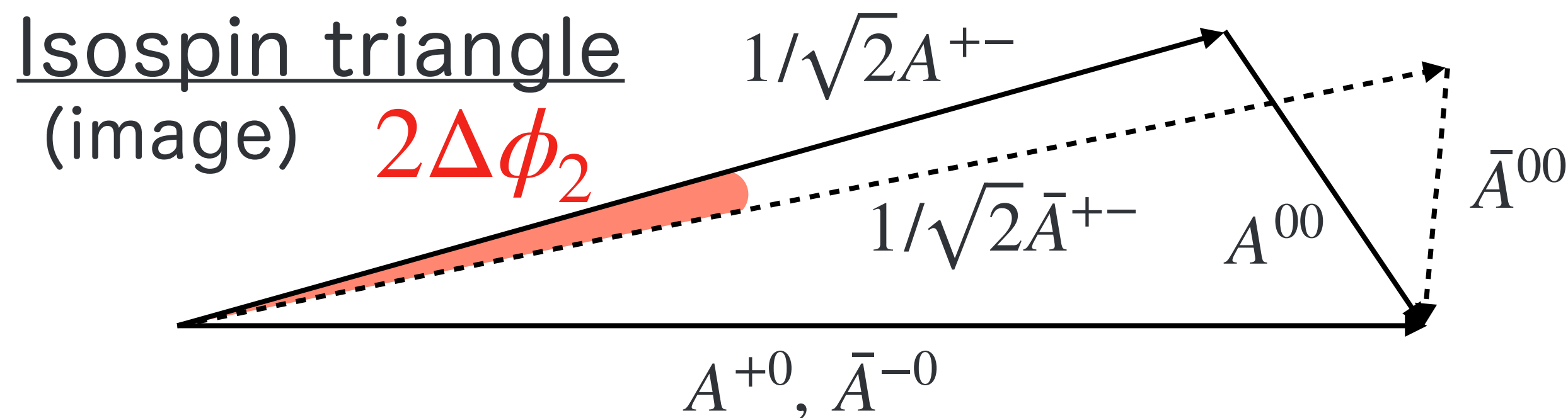

BF($\rho^0 \rho^0$) is extremely small.

- $A^{+0} \sim A^{+-}/\sqrt{2} \rightarrow$ small $\Delta\phi_2$
- Smallness could be quantitatively evaluated by Babar and Belle.

[Particles detected in experiments]

$\pi^0 \pi^0$: 4 photons \Rightarrow Impossible to measure B vertex for a TD analysis: can't measure $\mathcal{S}^{\pi^0 \pi^0}$

- $\mathcal{S}^{B \rightarrow f}$ will be measurable by analyzing events with the π^0 Dalitz mode in the future.

$\rho^0 \rho^0$: 4 charged pions \Rightarrow possibly determine $\mathcal{S}^{\rho^0 \rho^0}$

- Large error in the latest results: $0.3 \pm 0.7(\text{stat.}) \pm 0.2(\text{syst.})$

Belle II's analyses for ϕ_2 measurement

	$\mathcal{B} (\times 10^{-6})$	A_{CP}	$\mathcal{L}_{\text{int}} \text{ fb}^{-1}$
$B^0 \rightarrow \pi^+ \pi^-$	✓		63
$B^0 \rightarrow \pi^0 \pi^0$	✓	✓	190
$B^+ \rightarrow \pi^+ \pi^0$	✓	✓	190
$B^0 \rightarrow \rho^+ \rho^-$	✓		190
$B^0 \rightarrow \rho^0 \rho^0$			
$B^+ \rightarrow \rho^+ \rho^0$	✓	✓	190

The measured results are in good agreement with world averages (WAs), and the systematic uncertainties are well understood.

$$B^0 \rightarrow \pi^+ \pi^-: \text{BF} = (5.8 \pm 0.7 \text{ (stat.)} \pm 0.3 \text{ (syst.)}) \times 10^{-6} \quad \text{WA: } (5.12 \pm 0.19) \times 10^{-6}$$

$$B^0 \rightarrow \rho^0 \rho^0$$

- # of events is currently too small to measure A_{CP} due to the small branching fraction.
- At Belle, 166 ± 59 events w/ 711 fb^{-1}

$B^0 \rightarrow \pi^0 \pi^0$

- ◆ Continuum suppression ($e^+e^- \rightarrow q\bar{q}$; $q=u, d, s, \text{ and } c$)
 - Continuum particles collimated due to the large available momentum for the light-hadron decays.
 - Multivariate analysis (MVA) combining variables associated with event topology
 - Fast Boosted Decision Tree (FBDT): [Comput Softw Big Sci 1, 2 \(2017\)](#)
 - is applied to other analysis modes.
- ◆ 4 photons in the final state.
 - ⇒ Major backgrounds from fake photons rejected by the additional dedicated FBDT.
- ◆ Need to know flavor of B^0 (or \bar{B}^0) for A_{CP} ⇒ Flavor classification efficiency: $(30.0 \pm 1.3\%)$

arXiv:2110.00790

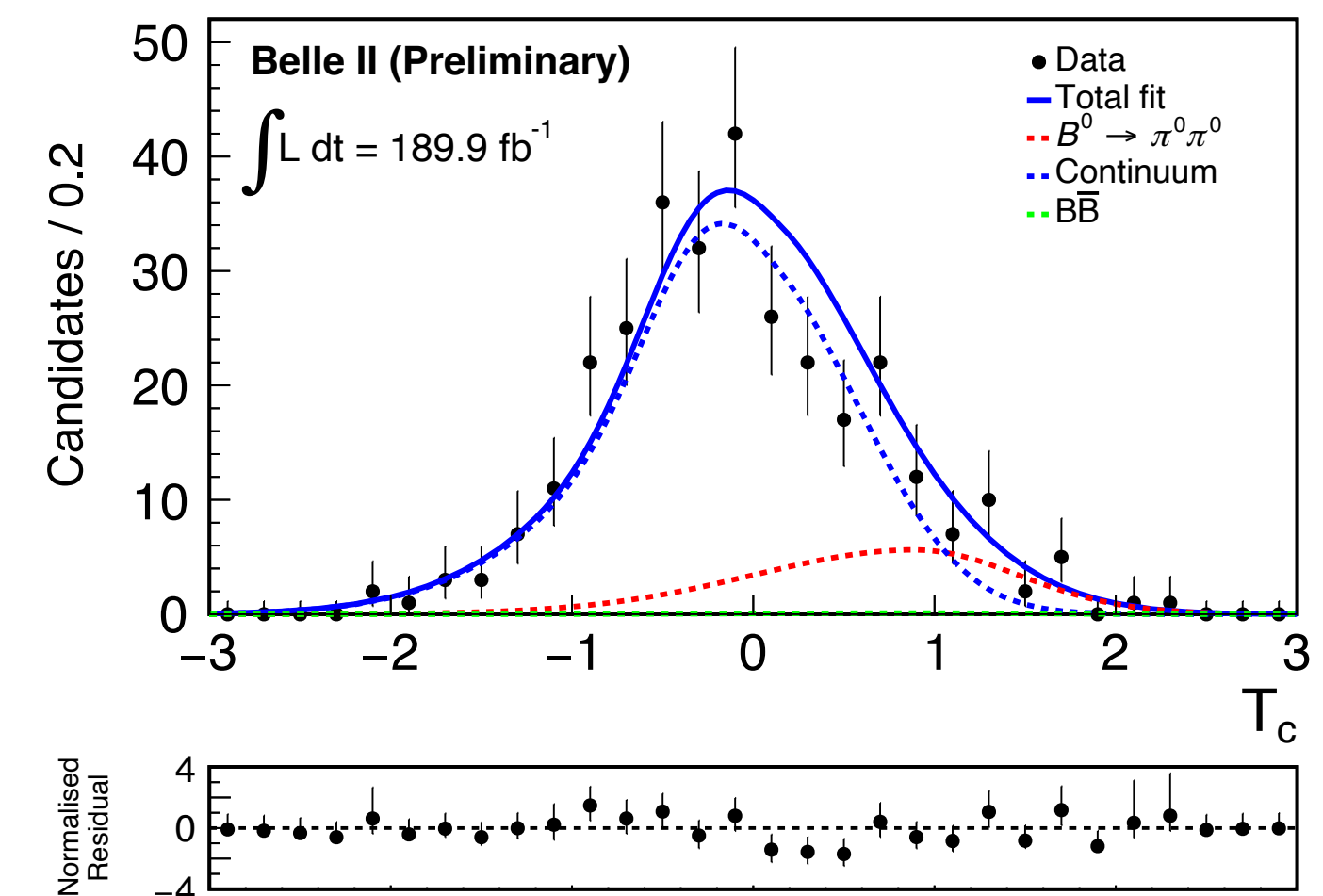
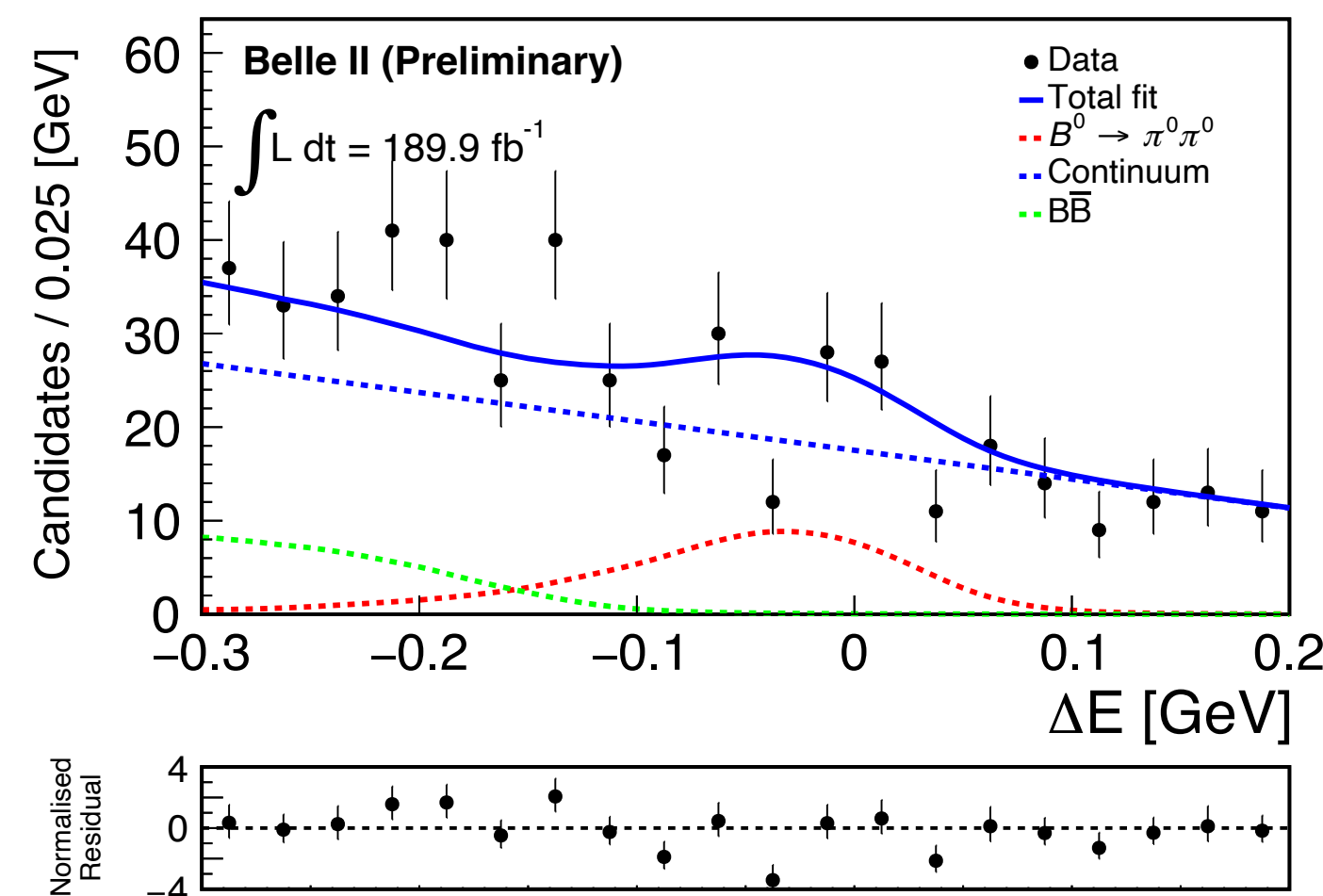
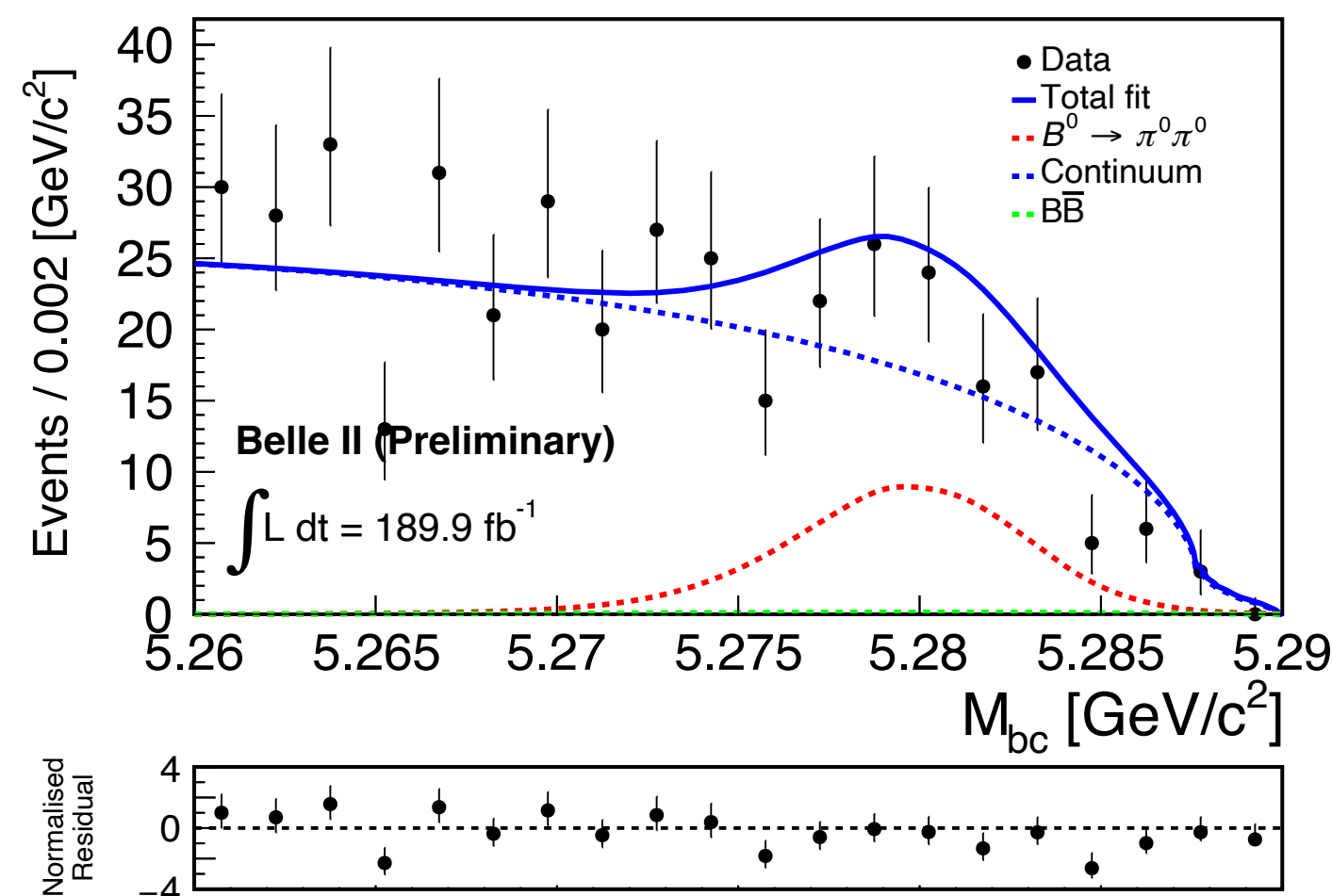

$B^0 \rightarrow \pi^0 \pi^0$

- ◆ 3D fit simultaneous in 7 bins of the flavor classification quality

M_{bc} : invariant mass of B candidates whose energy is replaced by half of collision energy.

ΔE : difference between half of collision energy and observed B energy

T_c : converted MVA output

- ◆ Results competitive with Belle

- ~1/3 of Belle's data set
- statistical error dominant

$$\mathcal{A}^{CP} = 0.14 \pm 0.46(\text{stat.}) \pm 0.07(\text{syst.})$$

$$\mathcal{B} = (1.27 \pm 0.25(\text{stat.}) \pm 0.17(\text{syst.})) \times 10^{-6}$$

$$\text{WA: } \mathcal{A}^{CP} = 0.33 \pm 0.22, \mathcal{B} = (1.59 \pm 0.26) \times 10^{-6}$$

Yield: 93 ± 18

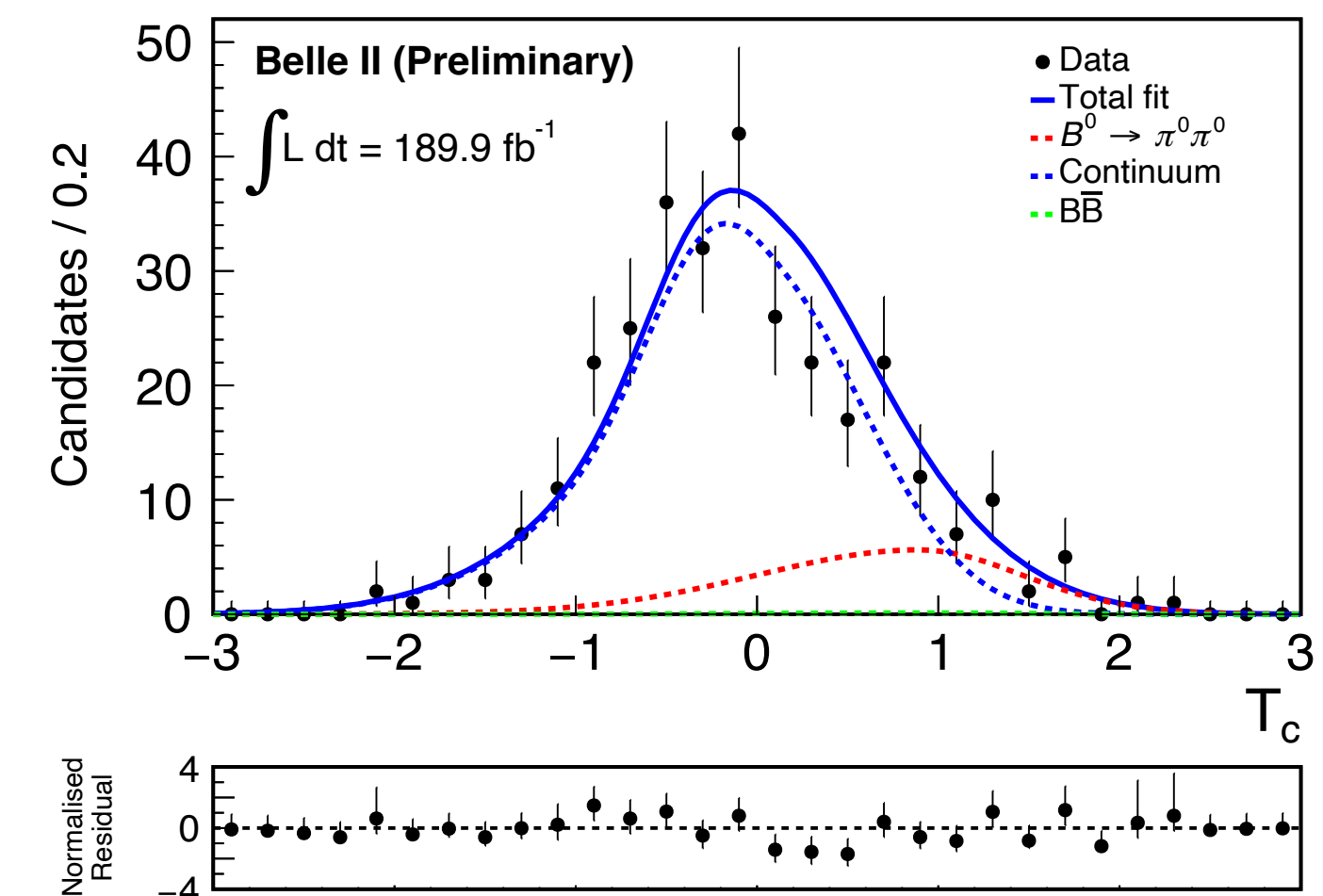
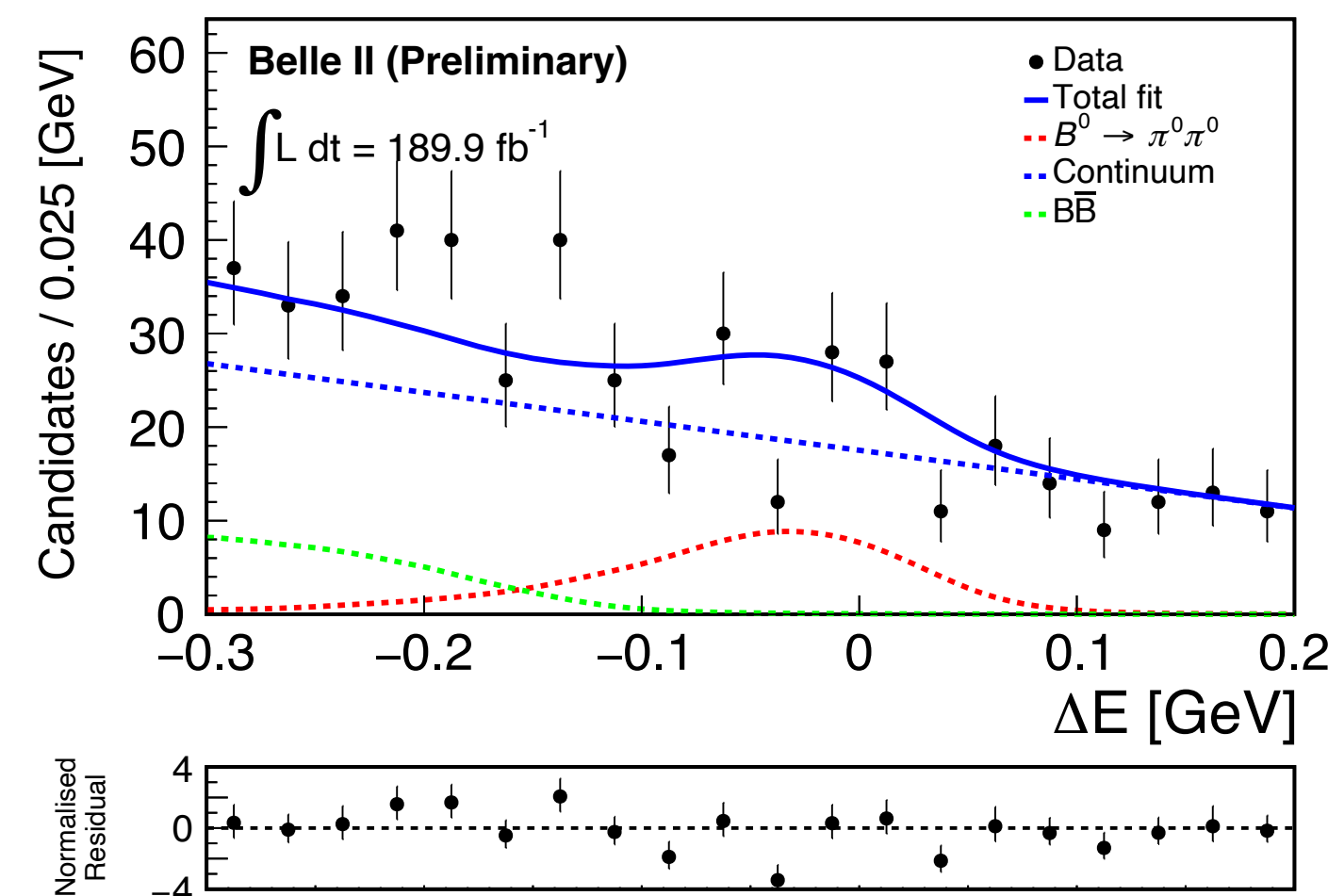
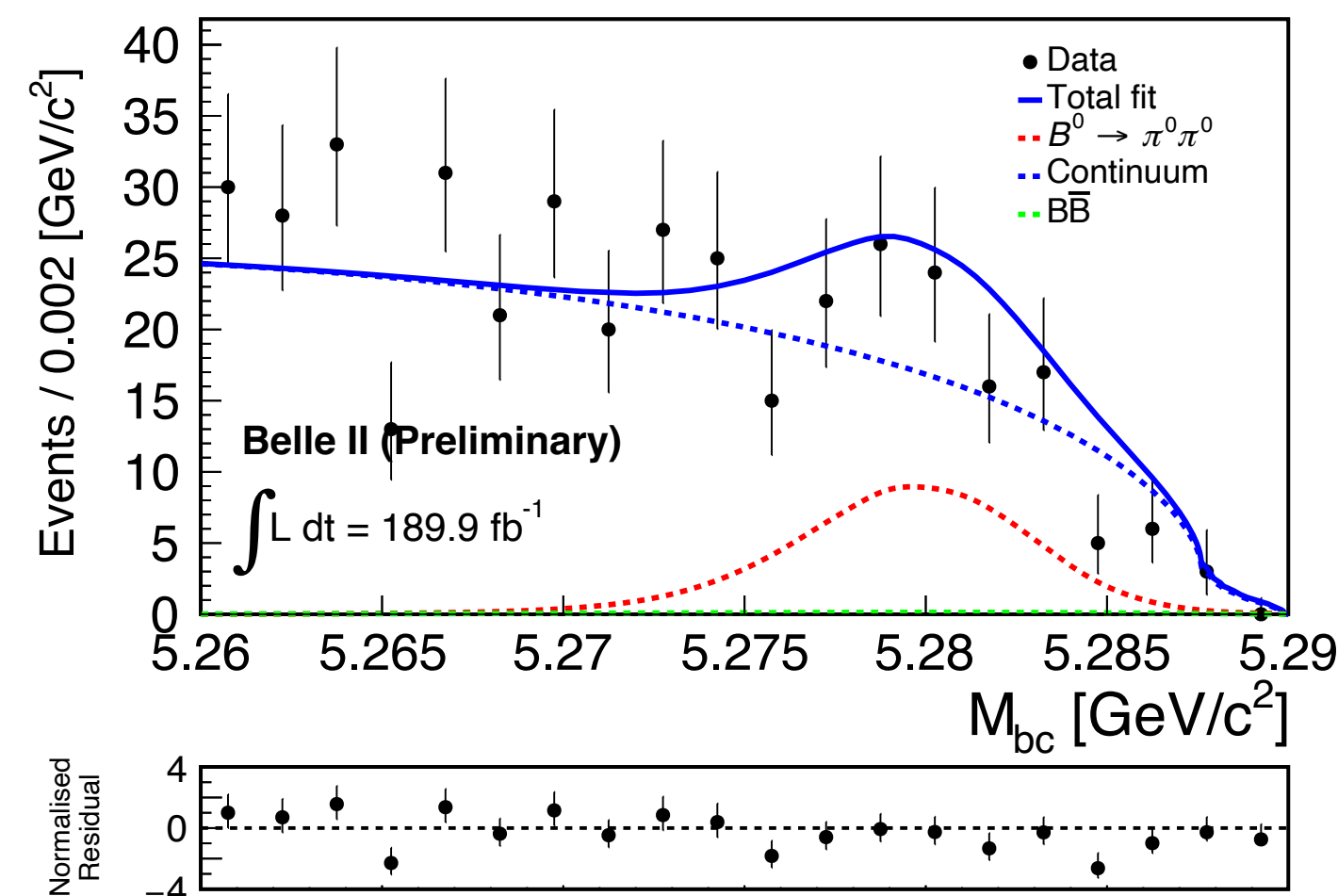

$B^+ \rightarrow \pi^+ \pi^0$

- ◆ Reconstruct $B^+ \rightarrow K^+ \pi^0$ and $B^+ \rightarrow \pi^+ \pi^0$ events using common selection. Yield: 422 ± 37
 - $B^+ \rightarrow K^+ \pi^0$: $K\pi$ puzzle
- ◆ Divide into pion- and kaon-enhanced samples.
- ◆ 3D charge-specific simultaneous fitting
 - To determine the CP asymmetry
 - M_{bc} , ΔE , converted MVA output
- ◆ K - π mis-identification negatively shifts the peak of ΔE .
 - $B \rightarrow \pi \pi$ can be clearly separated from $B \rightarrow K \pi$

$$\mathcal{A}^{CP} = -0.085 \pm 0.085(\text{stat.}) \pm 0.019(\text{syst.})$$

$$\mathcal{B} = (6.12 \pm 0.53(\text{stat.}) \pm 0.53(\text{syst.})) \times 10^{-6}$$

$$\text{WA: } \mathcal{A}^{CP} = 0.03 \pm 0.04, \mathcal{B} = (5.5 \pm 0.4) \times 10^{-6}$$

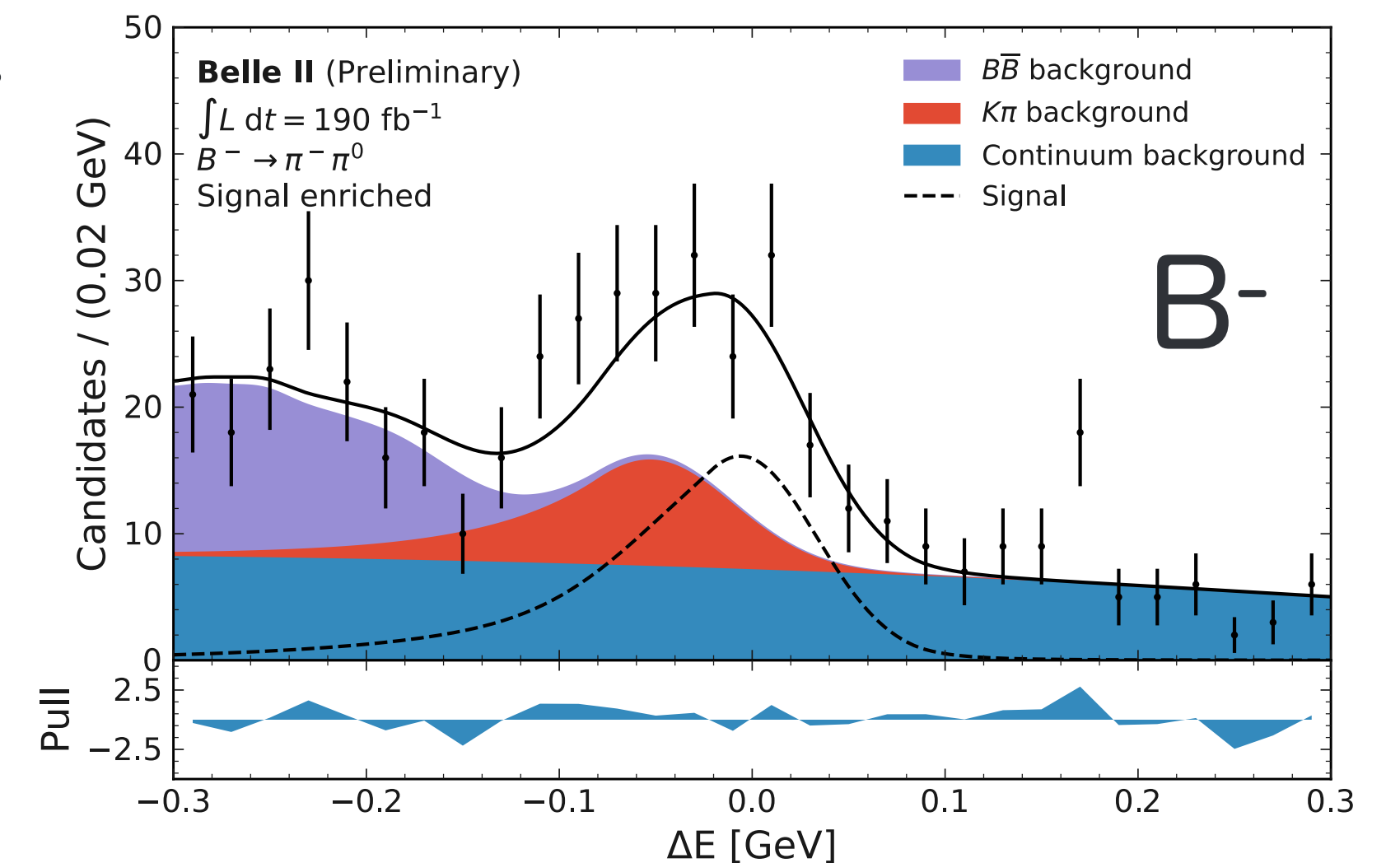
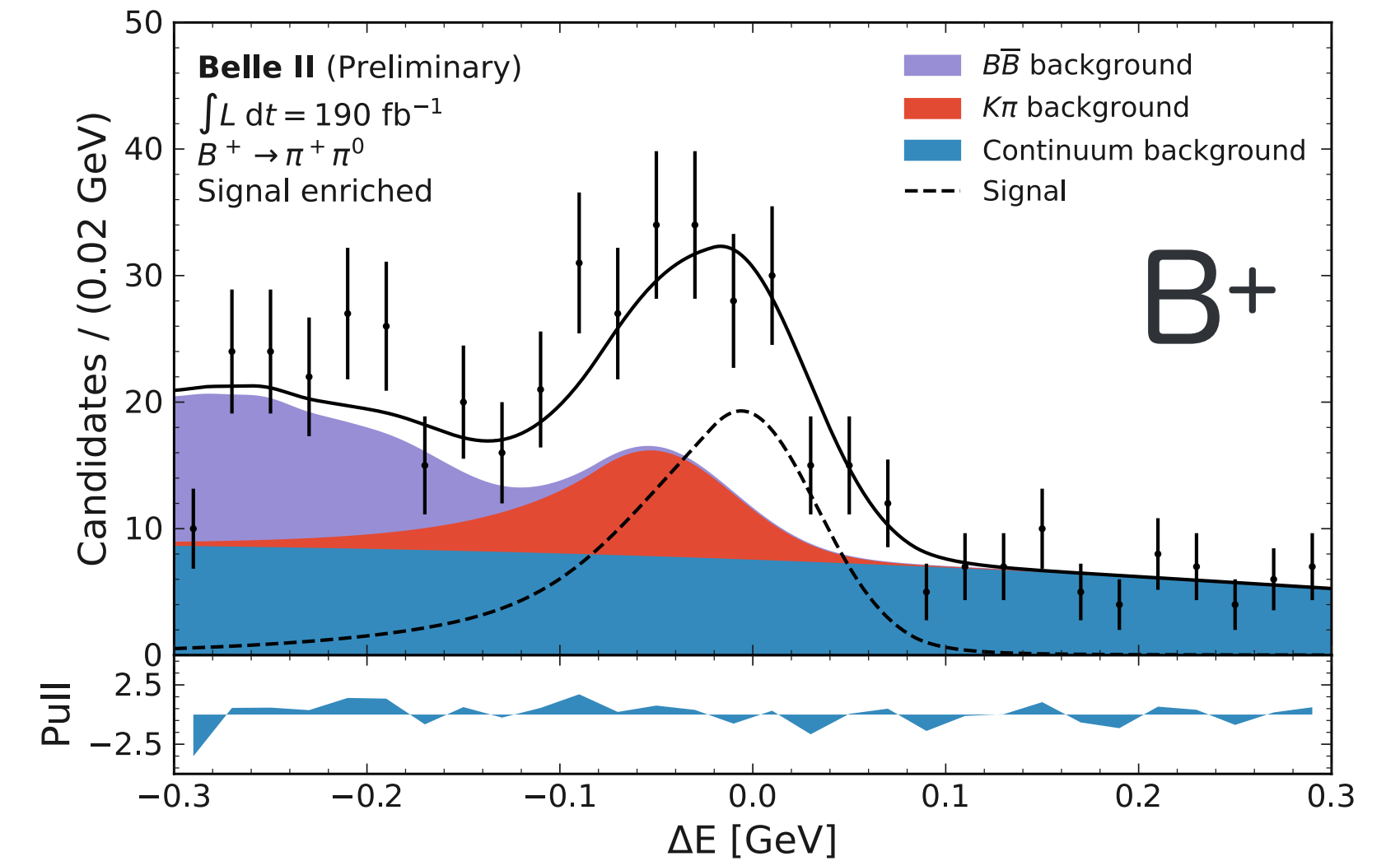

$B^0 \rightarrow \rho^+ \rho^-$

- ◆ $P \rightarrow VV$ decay
 - \Rightarrow need angular analysis to separate different polarizations
 - \Rightarrow fit helicity angle of $\rho^\pm \rightarrow \pi^\pm \pi^0$
- ◆ 6D (ΔE , T_C , $m_{\pi^\pm \pi^0}$, $\cos \theta_{\rho^\pm}$) fit taking correlations into account
 - 6 modes of peaking backgrounds have a similar final state as signal ($2\pi^0$, $1\pi^+ + 1h^-$)

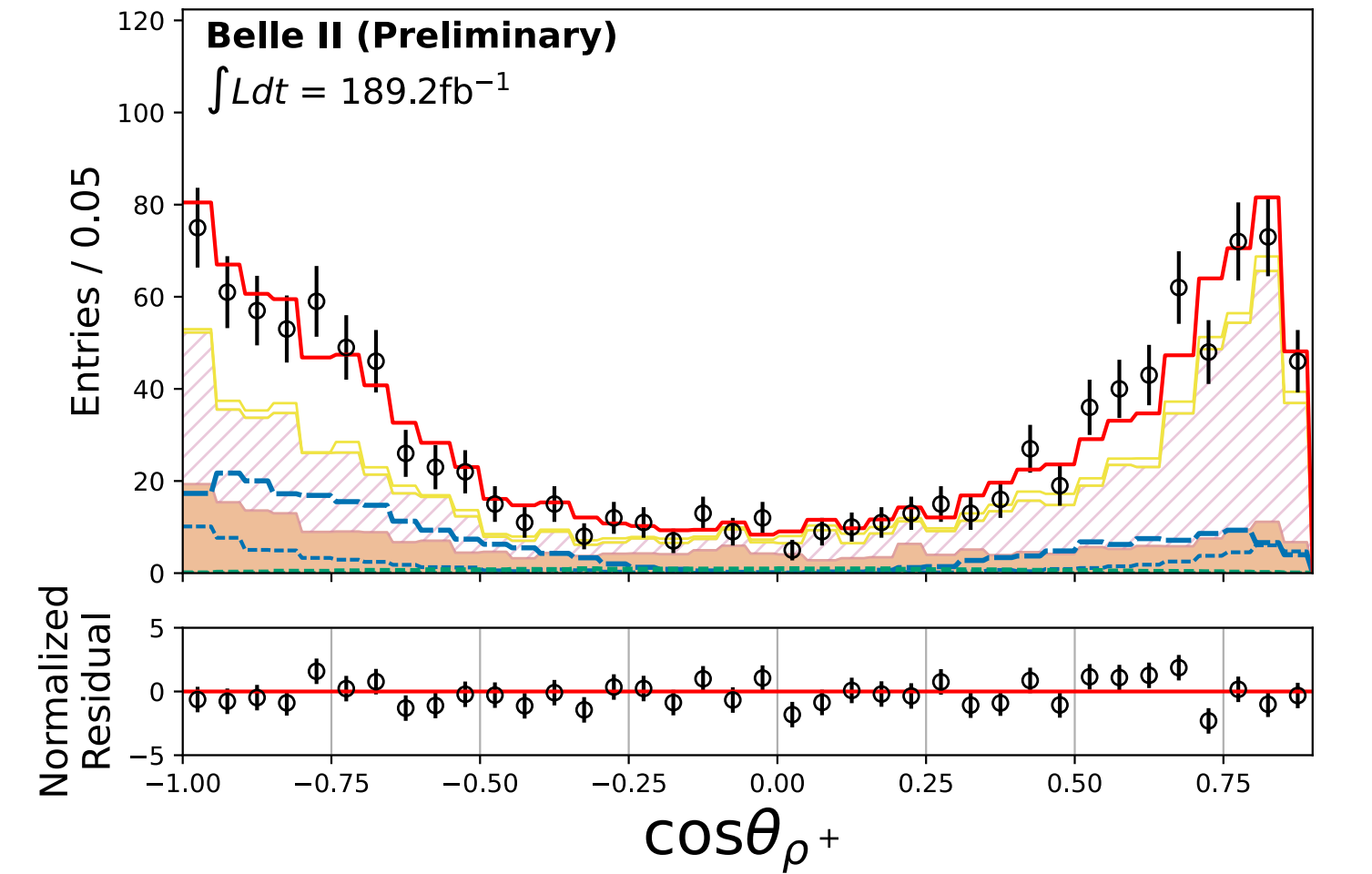
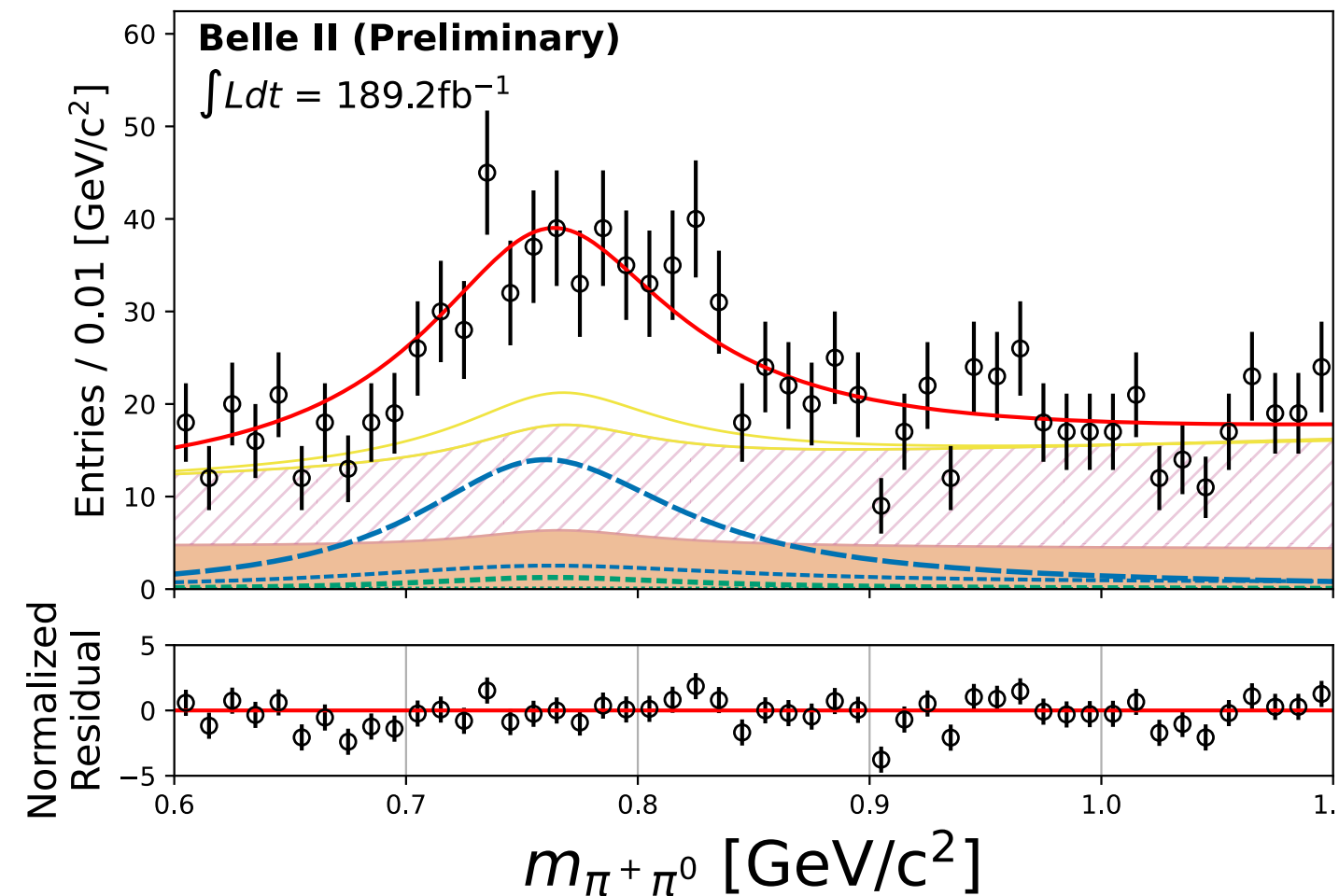
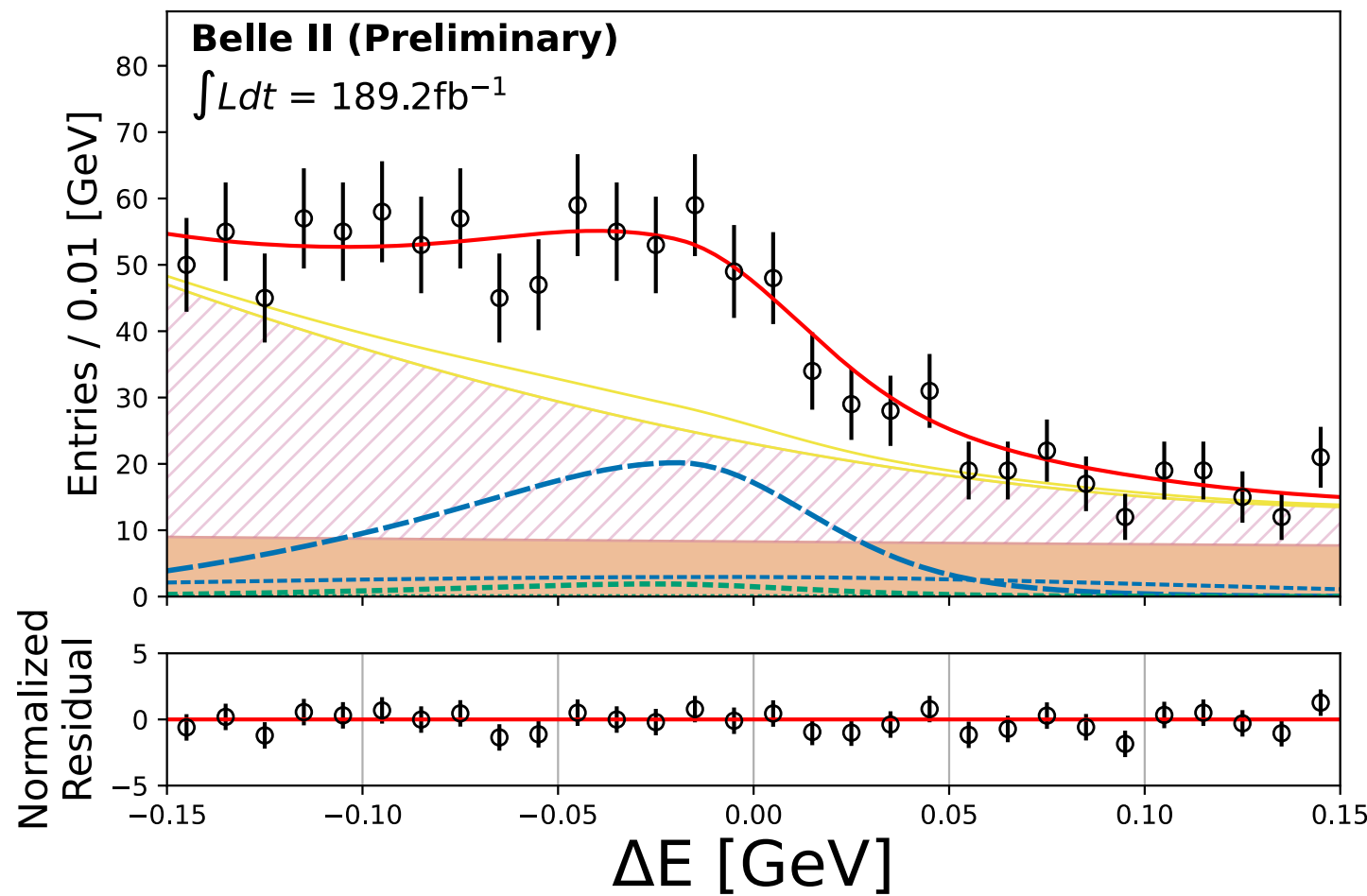
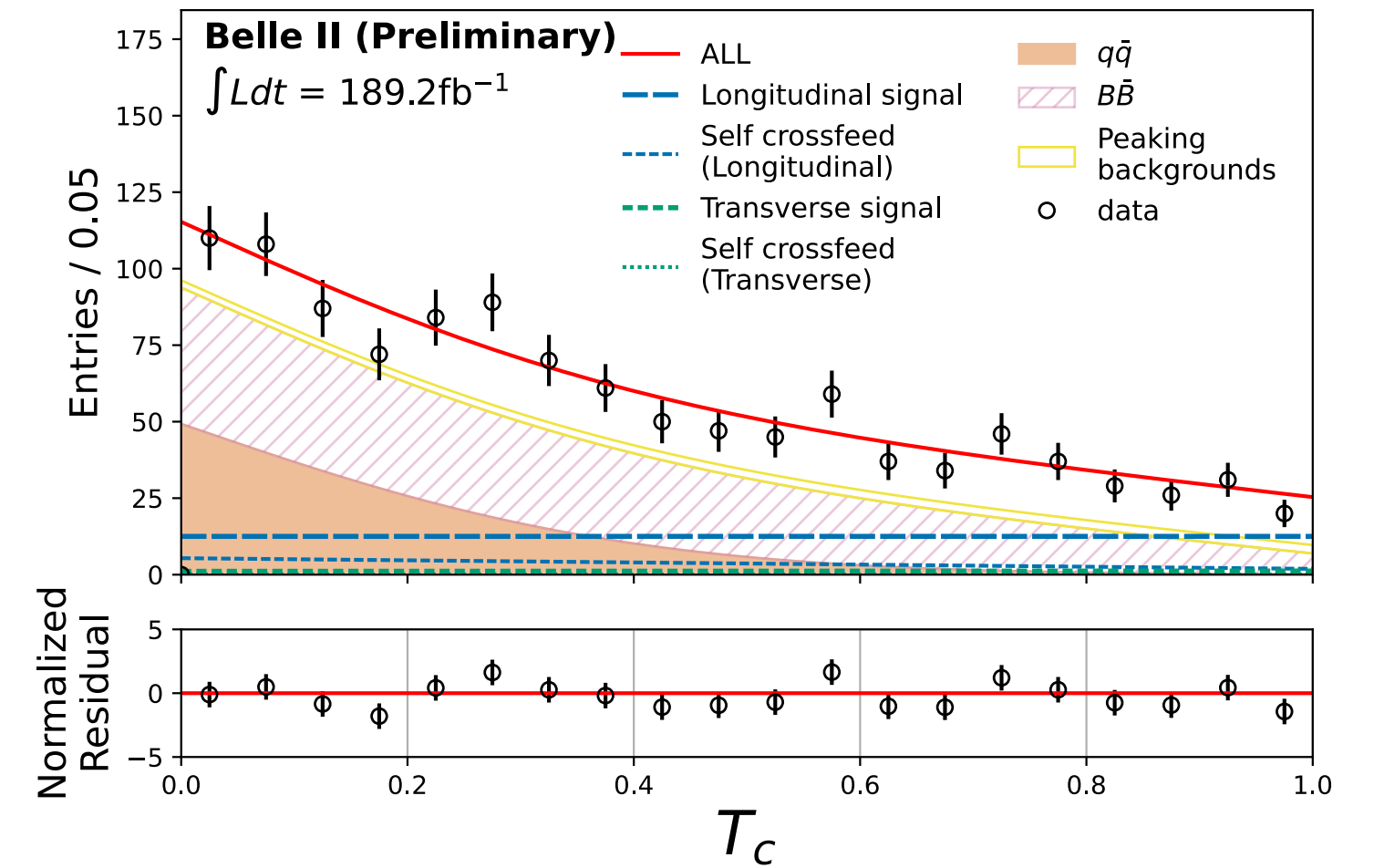
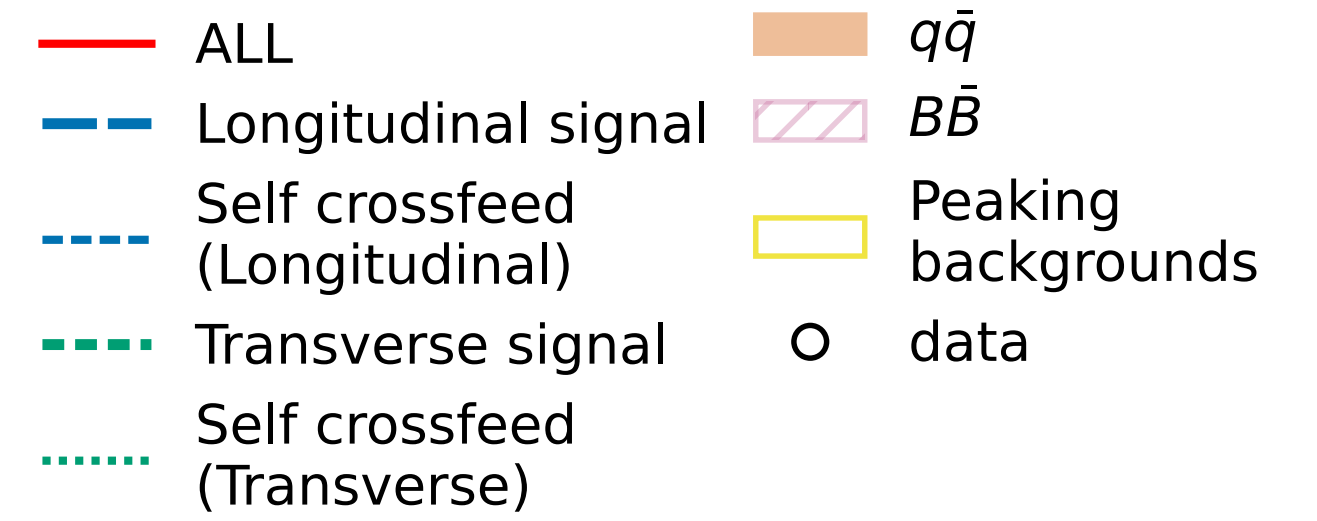



Yield: (long.) $234.6^{+23.7}_{-22.8}$, (trans.) $21.3^{+18.7}_{-17.3}$

$$\mathcal{B} = (26.7 \pm 2.8(\text{stat.}) \pm 2.8(\text{syst.})) \times 10^{-6}$$

$$f_L = 0.956 \pm 0.035(\text{stat.}) \pm 0.033(\text{syst.})$$

WA: $\mathcal{B} = (27.7 \pm 0.19) \times 10^{-6}$, $f_L = 0.990^{+0.021}_{-0.019}$

- ◆ Largest systematic uncertainty associated to π^0 reconstruction: 7.7% for BF

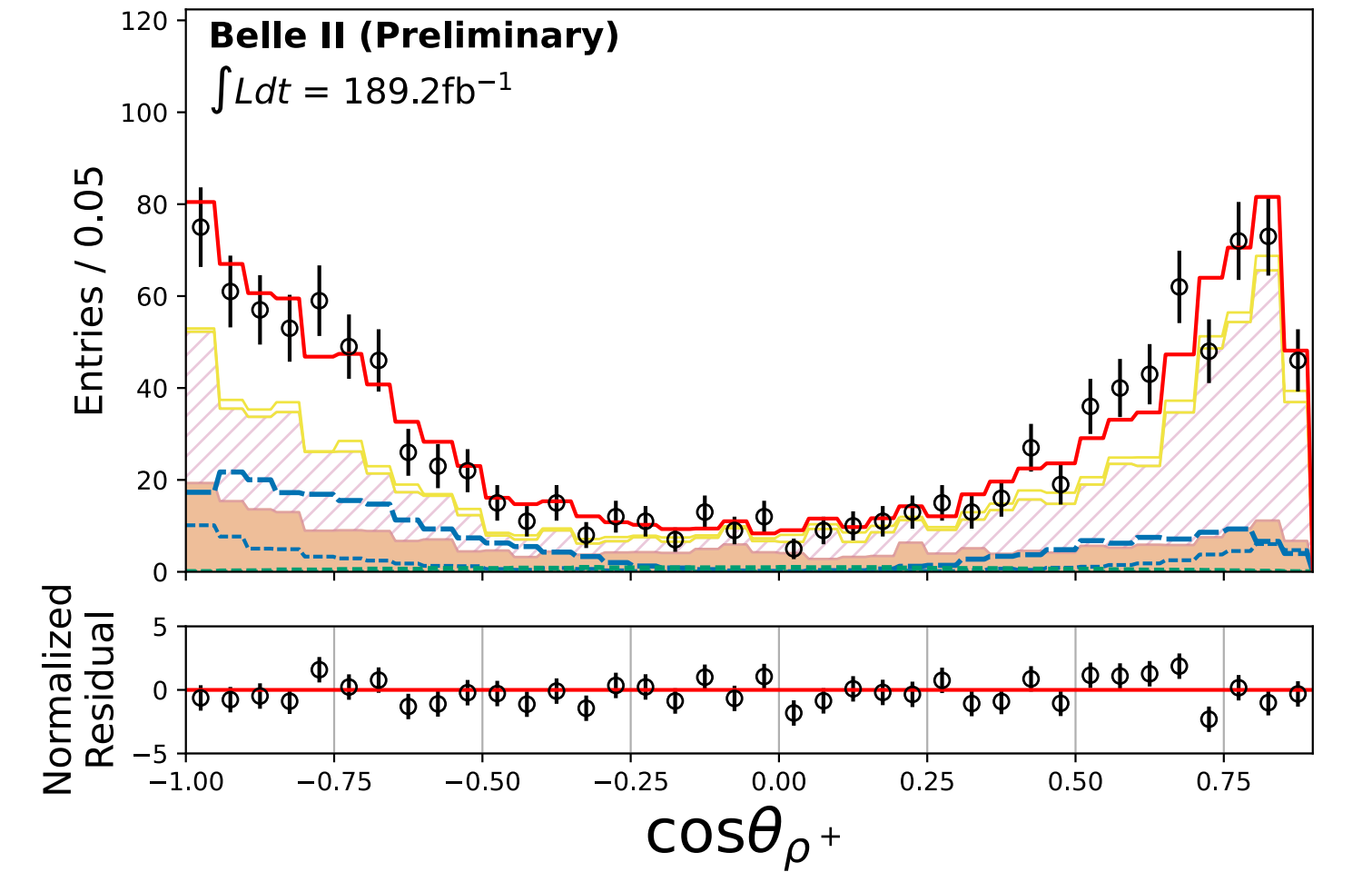
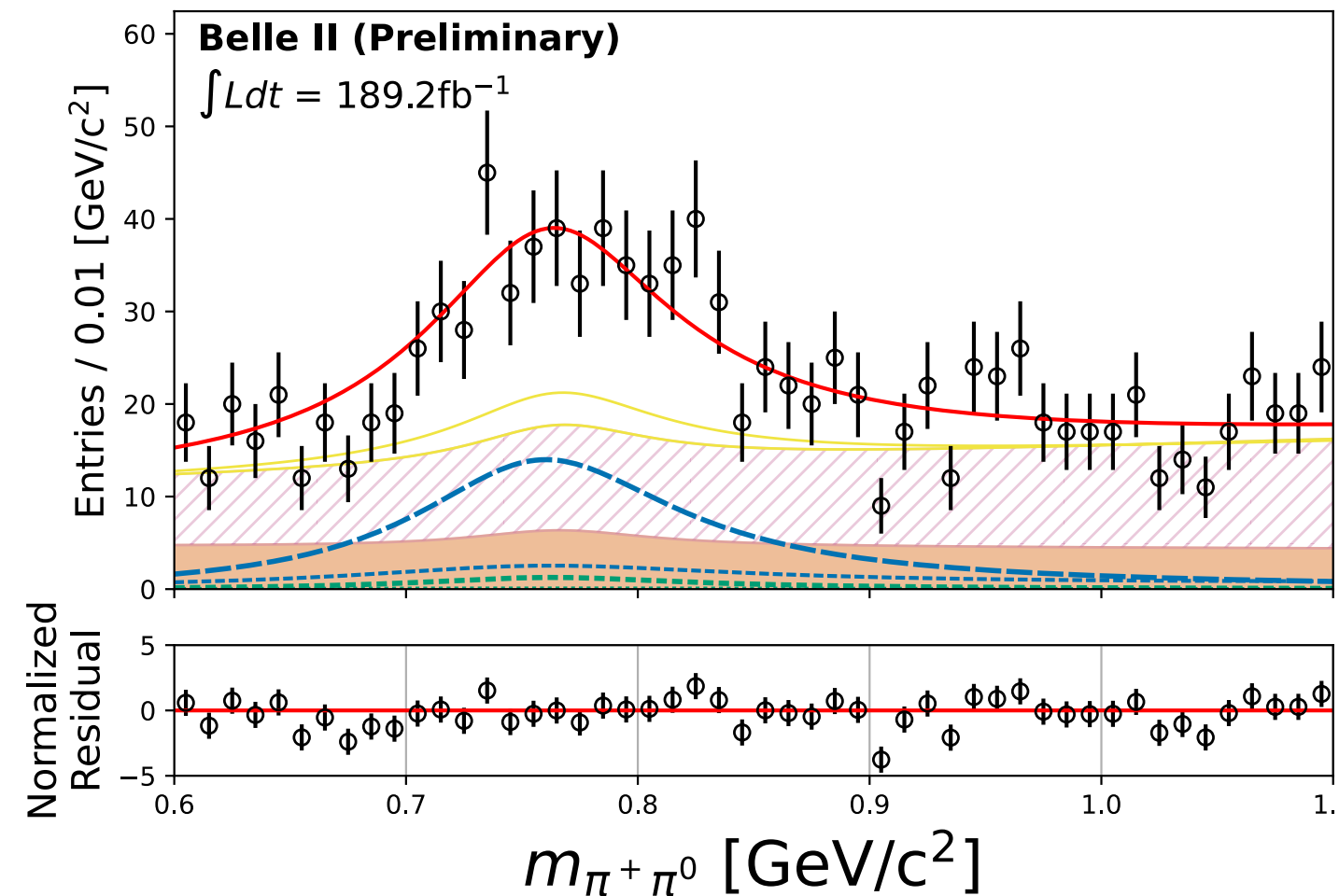
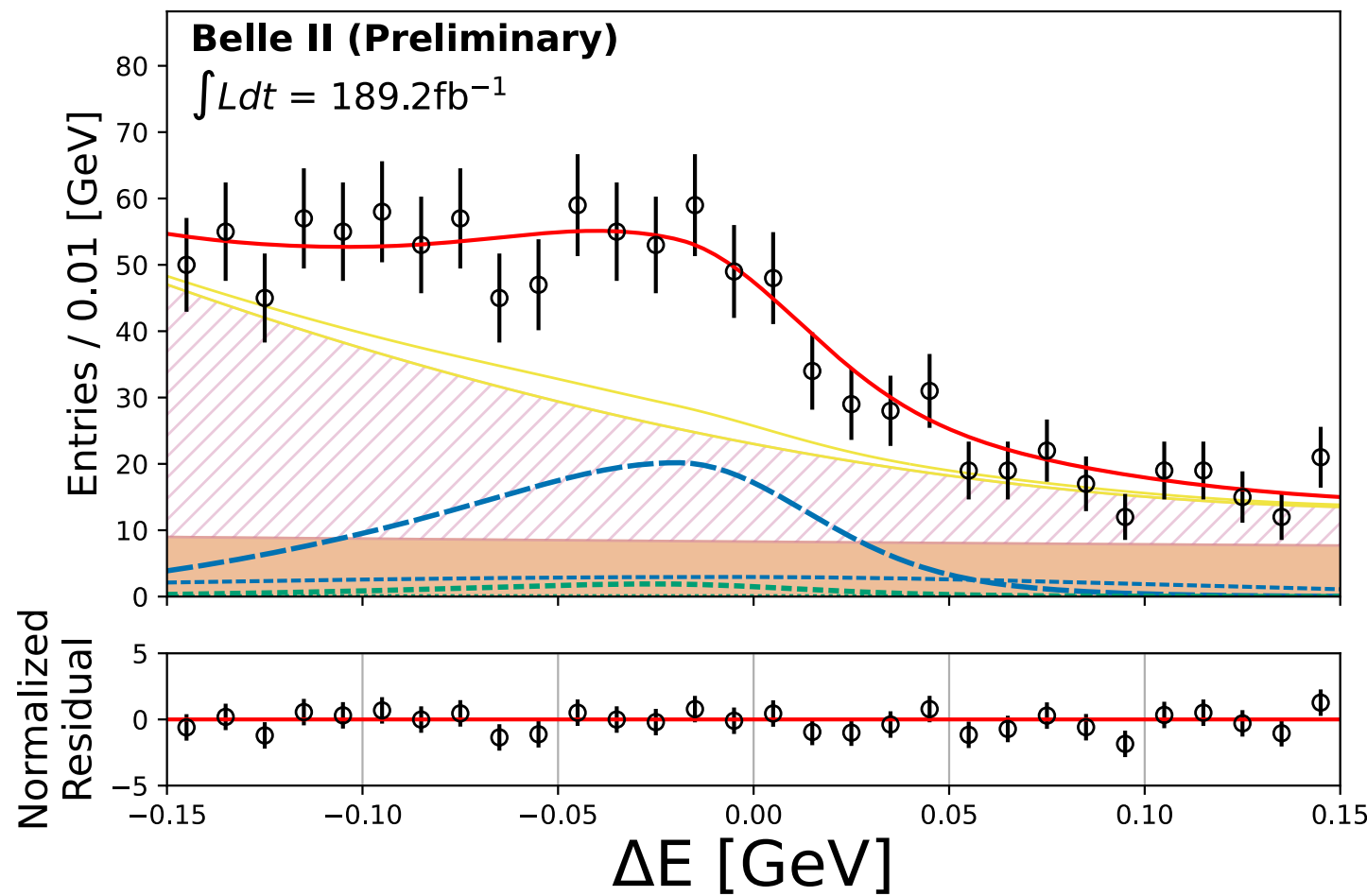
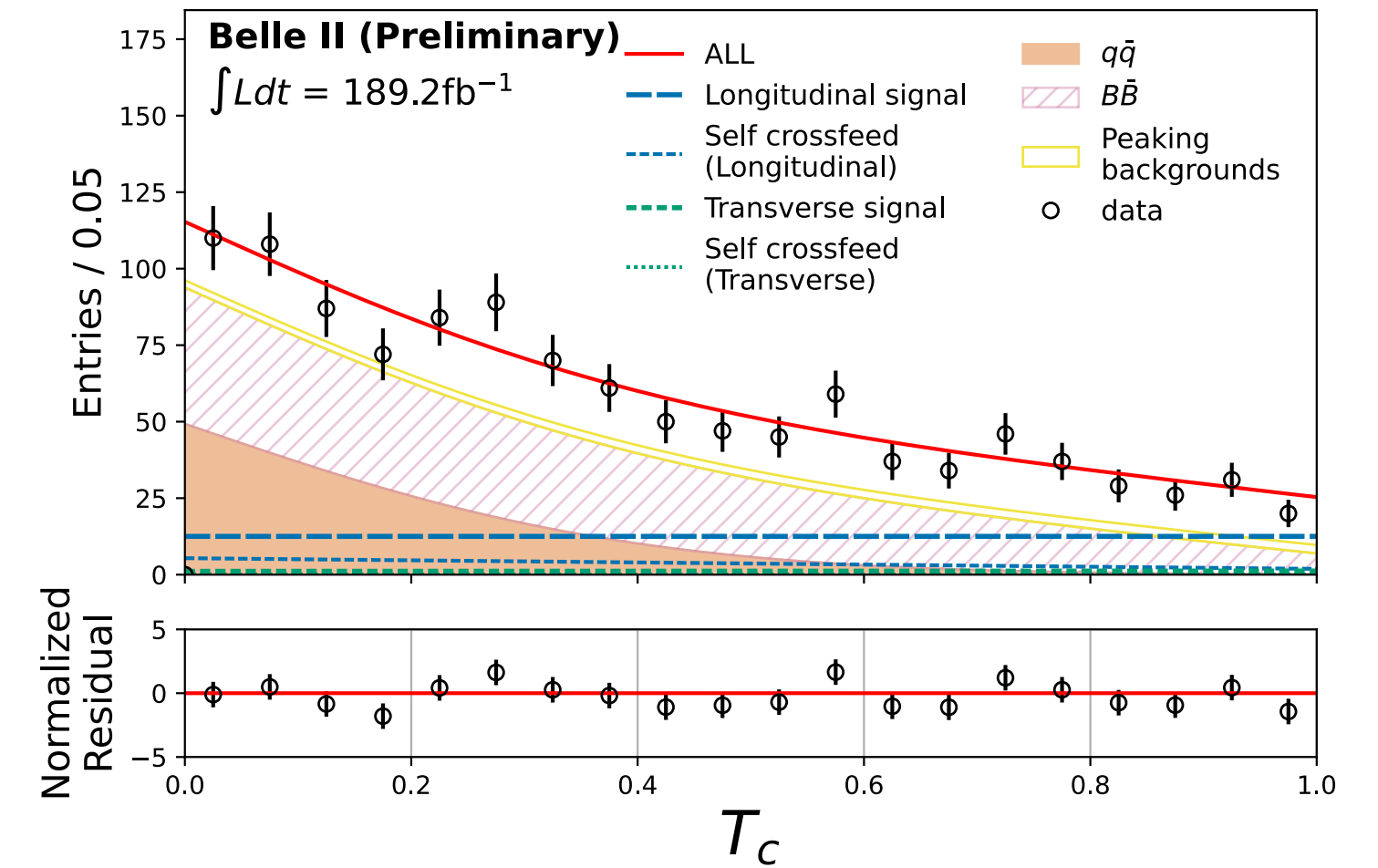
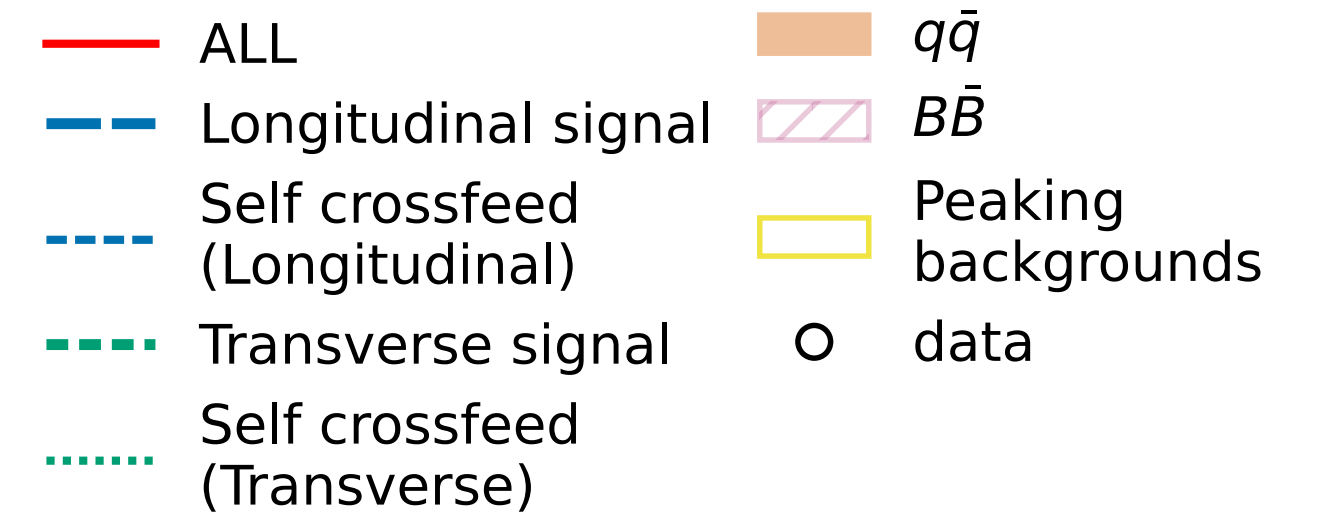

Yield: 345 ± 31

- ◆ Similar analysis strategy as $B^0 \rightarrow \rho^+ \rho^-$
- ◆ Fit helicity angle of $\rho \rightarrow \pi \pi$
 \Rightarrow Determine longitudinal-polarization fraction

$$\mathcal{A}^{CP} = -0.069 \pm 0.068(\text{stat.}) \pm 0.060(\text{syst.})$$

$$\mathcal{B} = (23.2_{-2.1}^{+2.2}(\text{stat.}) \pm 2.7(\text{syst.})) \times 10^{-6}$$

$$f_L = 0.943_{-0.033}^{+0.035}(\text{stat.}) \pm 0.027(\text{syst.})$$

$$\text{WA: } \mathcal{A}^{CP} = -0.05 \pm 0.05, \mathcal{B} = (24.0 \pm 1.9) \times 10^{-6}$$

$$f_L = 0.950 \pm 0.016$$

- ◆ Largest systematic uncertainty from data-simulation discrepancies of $\cos \theta_{\rho}$: 8.0% for BF
 - This is due to mis-modeling of low-p tracks in simulation.
 \Rightarrow We are trying to reduce this by reweighing on them.

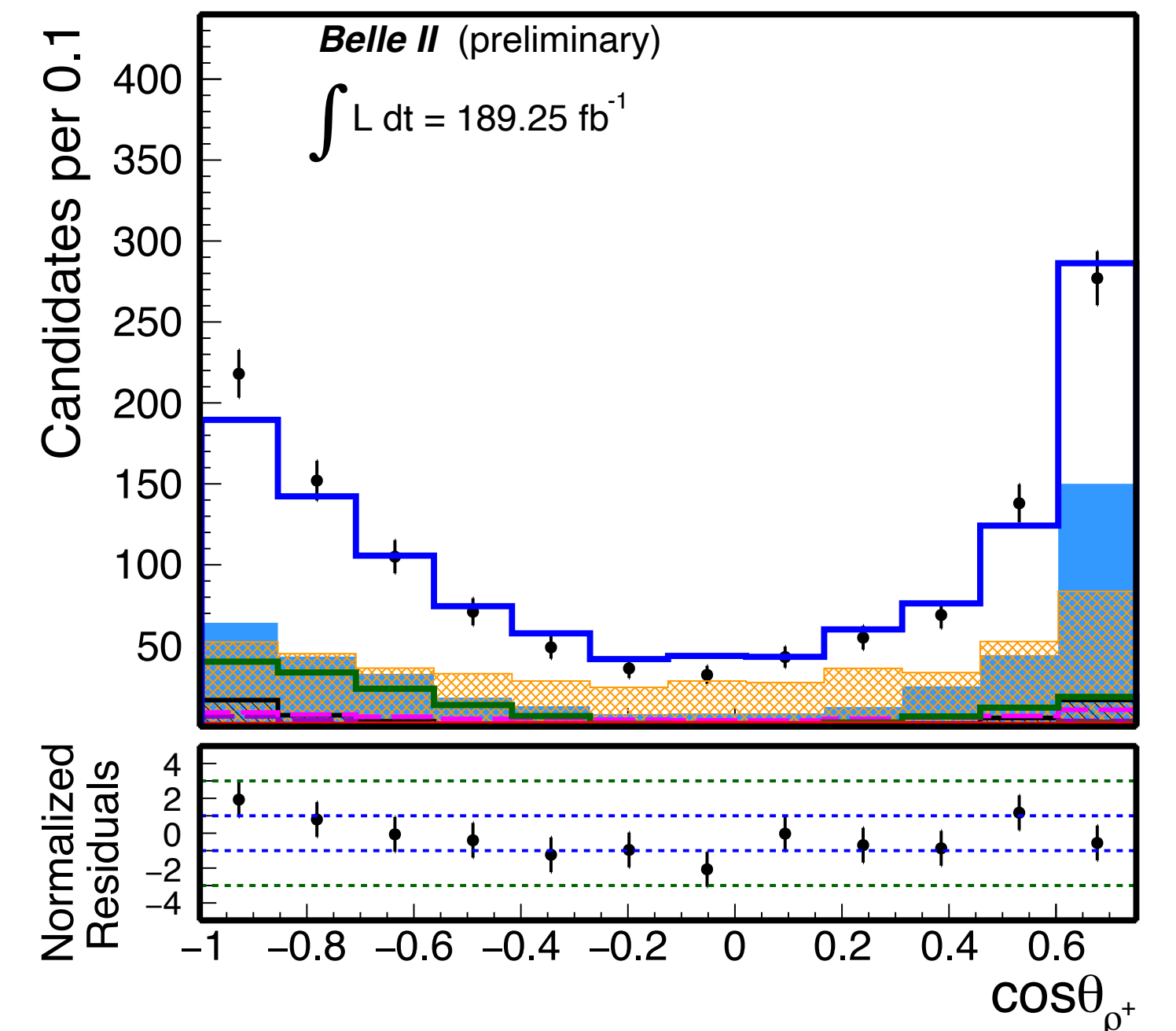
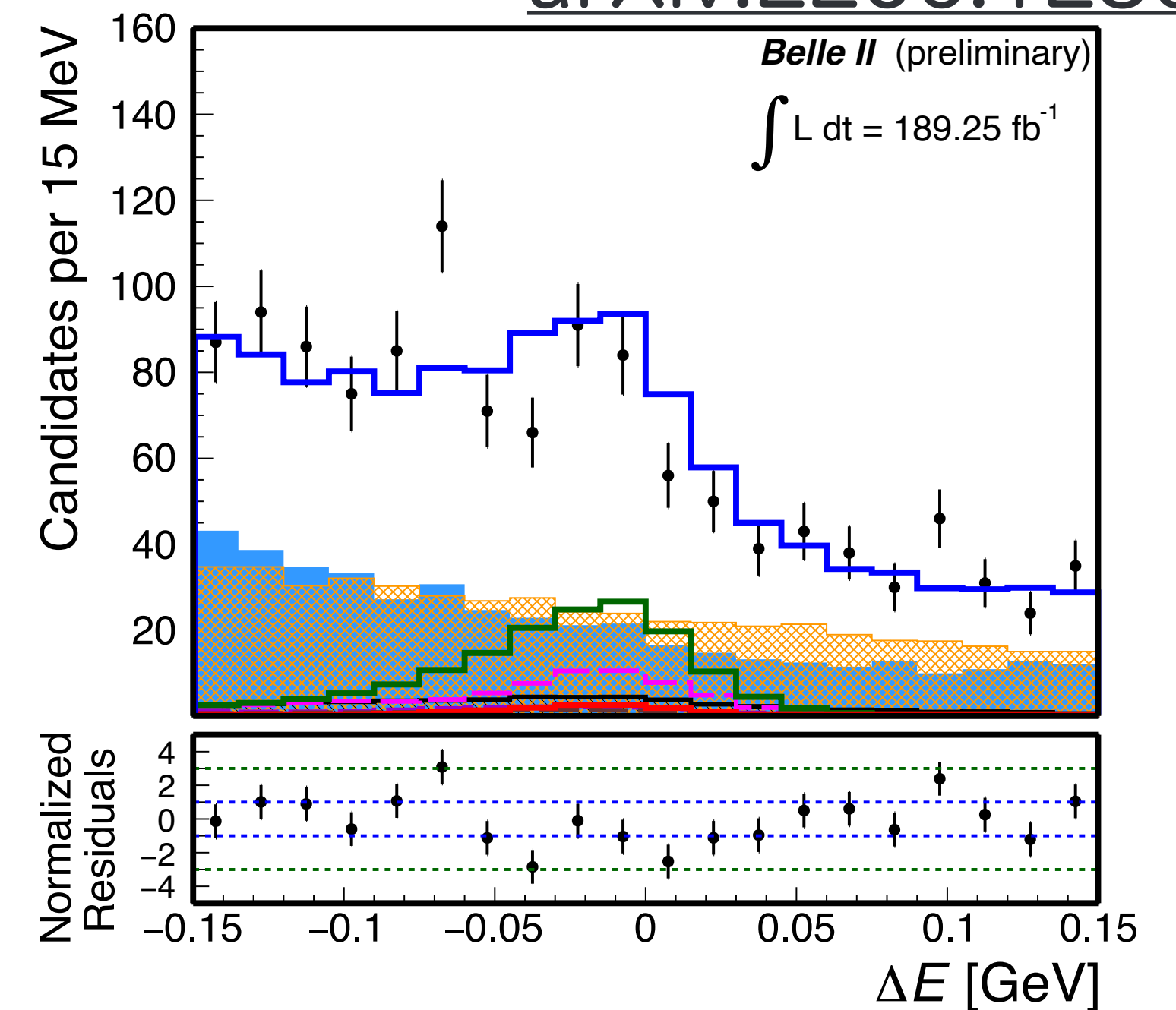

Prospects

- ◆ Before the end of 2022: \mathcal{L}_{int} of 363 fb^{-1} at $\Upsilon(4S)$
 - half of the integrated luminosity at Belle
- ◆ Winter and summer 2023: many updates w/ 363 fb^{-1}
- ◆ Autumn 2023: resume physics running
 - In about one year, the data size will be the same as Belle's, and
 - the accuracy of the ϕ_2 determination may be improved by applying upgraded analysis technique.
 - Combined analysis of Belle and Belle II data is also available.
- ◆ Excellent ϕ_2 precision with 50 ab^{-1} : $\Delta \phi_2 = 0.6 \sim 1.0^\circ$
 - Current WA: $(85.2^{+4.8}_{-4.3})^\circ$
 - $B \rightarrow \pi \pi$: $\Delta \phi_2 = \sim 2^\circ$
 - $B \rightarrow \rho \rho$: $\Delta \phi_2 = 0.7 \sim 1.0^\circ$

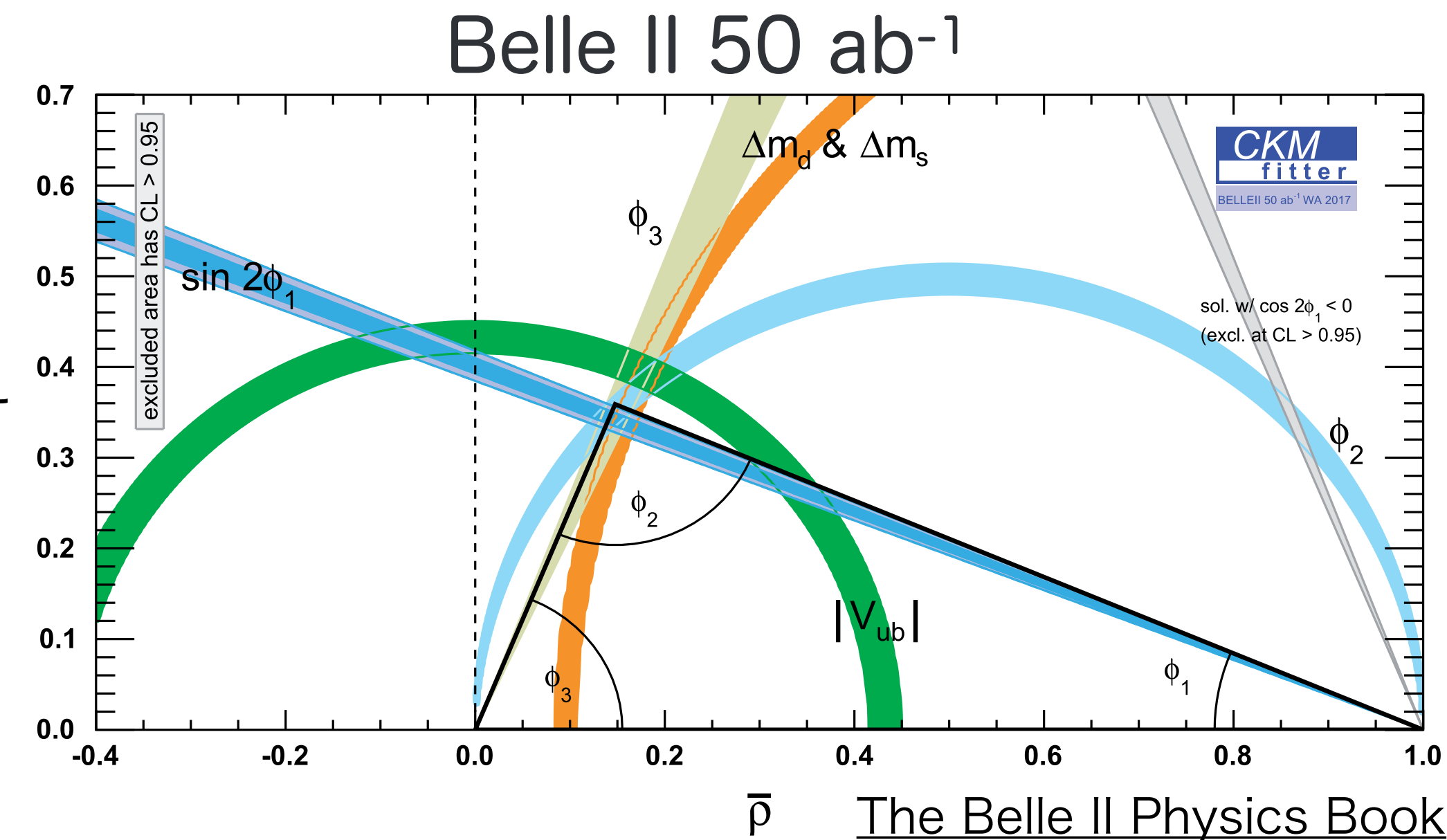
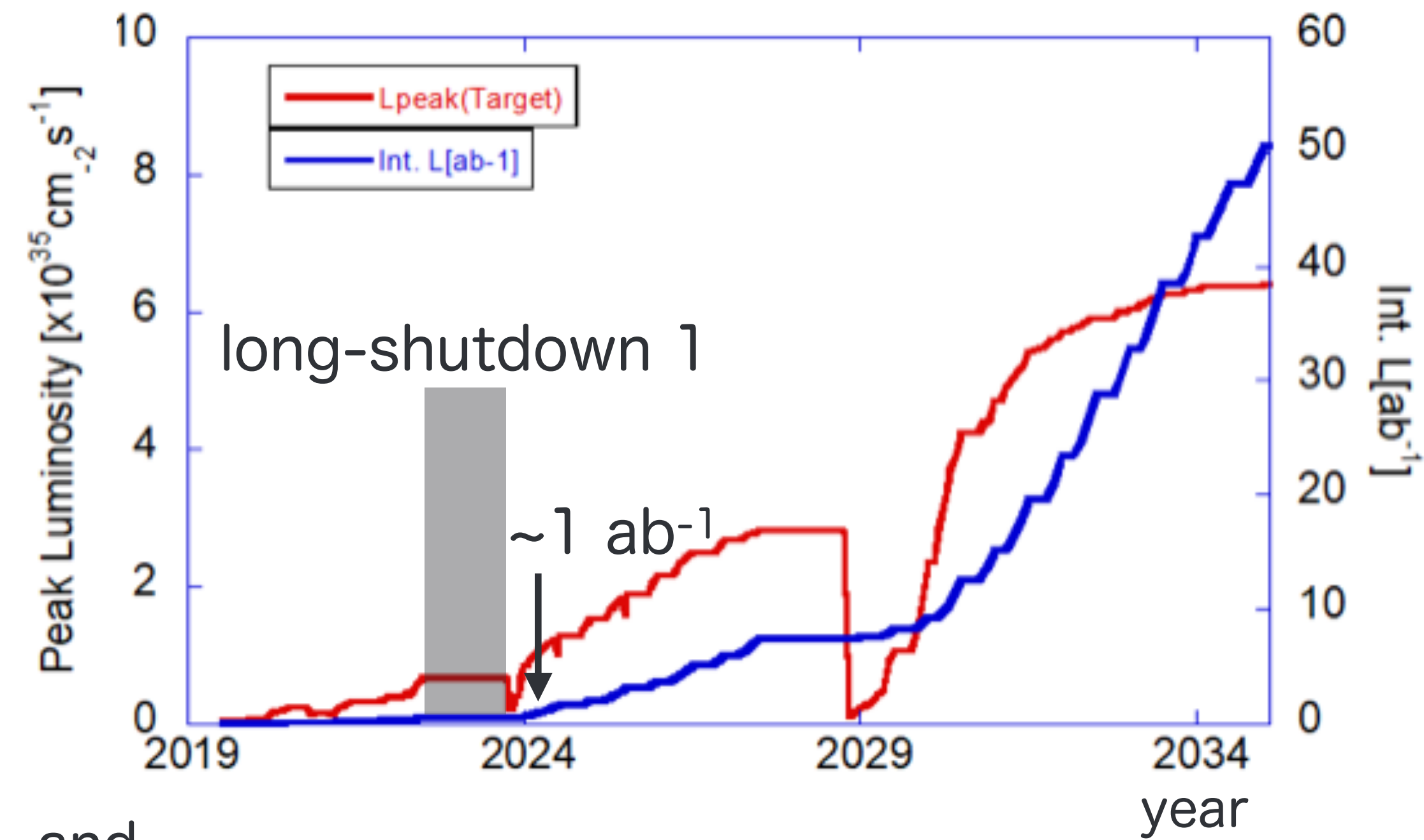

$\bar{\rho}$ The Belle II Physics Book

Summary

- ◆ In CKM, ϕ_2 is the least known parameter due to difficulties in analysis and should be precisely determined.
- ◆ Belle II is updating $B \rightarrow \pi \pi / \rho \rho$ measurements to determine ϕ_2 .
 - Analysis of five of the six modes is ongoing with updated results at Belle II.
 - $B^0 \rightarrow \rho^0 \rho^0$ will be measured to check its small branching fraction.

	$\mathcal{B} (\times 10^{-6})$	A_{CP}	$\mathcal{L}_{\text{int}} \text{ fb}^{-1}$
$B^0 \rightarrow \pi^+ \pi^-$	$5.8 \pm 0.7 \pm 0.3$ (5.12 ± 0.19)	($\mathcal{A} = -0.314 \pm 0.030, \mathcal{S} = -0.670 \pm 0.030$)	63
$B^0 \rightarrow \pi^0 \pi^0$	$1.27 \pm 0.25 \pm 0.17$ (1.59 ± 0.26)	$0.14 \pm 0.46 \pm 0.07$ (-0.33 ± 0.22)	190
$B^+ \rightarrow \pi^+ \pi^0$	$6.12 \pm 0.53 \pm 0.53$ (5.5 ± 0.4)	$0.085 \pm 0.085 \pm 0.019$ (0.03 ± 0.04)	190
$B^0 \rightarrow \rho^+ \rho^-$	$26.7 \pm 2.8 \pm 2.8$ (27.7 ± 1.9)	($\mathcal{A} = 0.00 \pm 0.09, \mathcal{S} = -0.14 \pm 0.13$)	190
$B^0 \rightarrow \rho^0 \rho^0$	(0.96 ± 0.15)	($\mathcal{A} = 0.2 \pm 0.9, \mathcal{S} = 0.3 \pm 0.7$)	-
$B^+ \rightarrow \rho^+ \rho^0$	$23.2^{+2.2}_{-2.1} \pm 2.7$ (24.0 ± 1.9)	$-0.069 \pm 0.068 \pm 0.060$ (-0.05 ± 0.05)	190

PDG2022
(World Averages)

Summary

- ◆ In CKM, ϕ_2 is the least known parameter due to difficulties in analysis and should be precisely determined.
- ◆ Belle II is updating $B \rightarrow \pi \pi / \rho \rho$ measurements to determine ϕ_2 .
 - Analysis of five of the six modes is ongoing with updated results at Belle II.
 - $B^0 \rightarrow \rho^0 \rho^0$ will be measured to check its small branching fraction.
- ◆ Our measurements already show performance equal to or better than the best results from Babar and Belle.
- ◆ In the coming years, we plan to achieve the world highest precision measurement.

Stay tuned!!

Backup

$B^0 \rightarrow \pi^+ \pi^-$

- ◆ 2D fit simultaneously (M_{bc} and ΔE)
- ◆ K - π mis-identification negatively shifts a peak position.

$$\mathcal{B} = (5.8 \pm 0.7(\text{stat.}) \pm 0.3(\text{syst.})) \times 10^{-6}$$

$$\text{WA: } \mathcal{B} = (5.12 \pm 0.19) \times 10^{-6}$$

